

# **Attachment D**

**Draft Voluntary Planning Agreement and  
Public Benefit Offer**

# Planning Agreement

The Council of the City of Sydney

and

Markham Real Estate Partners (Green Square) Pty  
Limited

ACN 631 478 227

## CONTENTS

CLAUSE	PAGE
1. INTERPRETATION .....	1
1.1 Definitions .....	1
1.2 Rules for interpreting this document.....	6
2. APPLICATION OF THE ACT AND THE REGULATION .....	7
2.1 Application of this document .....	7
2.2 Public Benefits to be made by Developer .....	7
2.3 Application of sections 7.11, 7.12 and 7.24 of the Act .....	8
2.4 City rights.....	8
2.5 Explanatory note .....	8
3. OPERATION OF THIS PLANNING AGREEMENT .....	8
3.1 Commencement .....	8
4. WARRANTIES .....	8
4.1 Mutual warranties .....	8
4.2 Developer warranties .....	9
5. PUBLIC BENEFITS .....	9
5.1 Developer to provide Public Benefits .....	9
6. COMPLETION.....	9
6.1 Date of Completion .....	9
6.2 Developer completion notice .....	9
6.3 Inspection by the City .....	10
6.4 Non-completion of Public Benefits .....	11
7. INDEMNITY .....	11
8. DEFECTS LIABILITY.....	11
8.1 Security for Defects Liability Period .....	11
8.2 Defect in the Public Benefits.....	12
9. REGISTRATION AND CAVEAT .....	12
9.1 Registration of this document .....	12
9.2 Release of this document.....	13
10. ENFORCEMENT .....	13
10.1 Developer to provide Guarantee .....	13
10.2 Adjustment of Guarantee Amount.....	13
10.3 Right of City to claim on Guarantee.....	14
10.4 Expenditure by the City .....	14
10.5 Top-up and return of Guarantee .....	15
10.6 Compulsory acquisition.....	15
10.7 Addition.....	16
11. DISPUTE RESOLUTION .....	16
11.1 Application.....	16
11.2 Negotiation .....	16
11.3 Not use information .....	17
11.4 Condition precedent to litigation .....	17
11.5 Summary or urgent relief.....	17

12.	TAXES AND GST .....	17
	12.1 Responsibility for Taxes .....	17
	12.2 GST free supply .....	17
	12.3 Supply subject to GST .....	18
13.	DEALINGS.....	18
	13.1 Dealing by the City .....	18
	13.2 Dealing by the Developer.....	19
	13.3 Extinguishment or creation of interests on Transfer Land .....	19
14.	TERMINATION .....	20
15.	CONFIDENTIALITY AND DISCLOSURES .....	20
	15.1 Use and disclosure of Confidential Information .....	20
	15.2 Disclosures to personnel and advisers .....	20
	15.3 Disclosures required by law.....	21
	15.4 Receiving party's return or destruction of documents .....	21
	15.5 Security and control .....	22
	15.6 Media releases .....	22
16.	NOTICES .....	22
17.	GENERAL .....	22
	17.1 Governing law .....	22
	17.2 Access to information .....	22
	17.3 Liability for expenses.....	23
	17.4 Relationship of parties.....	23
	17.5 Giving effect to this document .....	23
	17.6 Time for doing acts .....	23
	17.7 Severance.....	23
	17.8 Preservation of existing rights .....	24
	17.9 No merger .....	24
	17.10 Waiver of rights.....	24
	17.11 Operation of this document.....	24
	17.12 Operation of indemnities.....	24
	17.13 Inconsistency with other documents.....	24
	17.14 No fetter.....	25
	17.15 Counterparts.....	25
1.	PUBLIC BENEFITS - OVERVIEW.....	29
2.	PAYMENT OF MONETARY CONTRIBUTION.....	30
	2.1 Payment.....	30
	2.2 Indexation .....	30
	2.3 Deductions.....	31
	2.4 No trust.....	31
3.	TRANSFER LAND.....	31
	3.1 Dedication of land – decision .....	31
	3.2 Obligations on dedication.....	31
	3.3 Obligations on transfer .....	32
4.	FINAL DESIGN OF THE DEVELOPER'S WORKS .....	32
	4.1 Scope of Developer's Works .....	32
	4.2 Developer's Works – Johnson Street .....	33
	4.3 Final design of Developer's Works and Attributed Value of Developer's Works – Johnson Street.....	34
	4.4 Preparation of and changes to construction design drawings .....	35

5.	CONSTRUCTION OF DEVELOPER’S WORKS.....	36
5.1	Insurance .....	36
5.2	Approvals and consents .....	37
5.3	Construction work.....	37
5.4	Inspections by the City .....	37
6.	STANDARDS.....	38

**Schedules**

1	Agreement Details .....	26
2	Requirements under the Act and Regulation (clause 2) .....	27
3	Public Benefits (clause 5).....	29

**THIS PLANNING AGREEMENT** is made on

2020.

**BETWEEN:**

- (1) **The Council of the City of Sydney** ABN 22 636 550 790 of Town Hall House, 456 Kent Street, SYDNEY NSW 2000 (the **City**); and
- (2) **Markham Real Estate Partners (Green Square) Pty Limited** ACN 631 478 227 of Level 9, 4-10 Martin Place Sydney NSW 2000 (the **Developer**).

**BACKGROUND**

- (A) The Developer is the owner of the Land.
- (B) The Developer has offered to enter into this document with the City to provide the Public Benefits on the terms of this document.

**THE PARTIES AGREE AS FOLLOWS:**

1. **INTERPRETATION**

1.1 **Definitions**

The following definitions apply in this document.

**Act** means the *Environmental Planning and Assessment Act 1979 (NSW)*.

**Adverse Affectation** has the same meaning as in Part 3 of Schedule 3 of the *Conveyancing (Sale of Land) Regulation 2010 (NSW)*.

**Attributed Value** means the value the City and the Developer agree is to be attributed to each element of the Public Benefits as at the date of this document, as set out in clause 1 of Schedule 3 of this document.

**Authorisation** means:

- (a) an approval, authorisation, consent, declaration, exemption, permit, licence, notarisation or waiver, however it is described, and including any condition attached to it; and
- (b) in relation to anything that could be prohibited or restricted by law if a Government Agency acts in any way within a specified period, the expiry of that period without that action being taken,

including any renewal or amendment.

**Business Day** means a day (other than a Saturday, Sunday or public holiday) on which banks are open for general banking business in Sydney, Australia.

**City's Personal Information** means Personal Information to which the Developer, or any third party engaged by the Developer, has access directly or indirectly in connection with this document, including the Personal Information of any personnel, customer or supplier of the City (other than the Developer).

**City's Policies** means all policies and procedures relevant to the provision of the Public Benefits, as notified by the City in writing to the Developer.

**City's Representative** means the person named in Item 3 of Schedule 1 or his/her delegate.

**Completion** means the point at which the Developer's Works are complete except for minor defects:

- (a) the existence of which do not prevent the Developer's Works being reasonably capable of being used for their intended purpose;
- (b) which the Developer has grounds for not promptly rectifying; and
- (c) rectification of which will not affect the immediate and convenient use of the Developer's Works for their intended purpose.

**Completion Notice** means a notice issued by the Developer in accordance with clause 6.1.

**Confidential Information** means:

- (a) information of a party (**disclosing party**) that is:
  - (i) made available by or on behalf of the disclosing party to the other party (**receiving party**), or is otherwise obtained by or on behalf of the receiving party; and
  - (ii) by its nature confidential or the receiving party knows, or ought reasonably to know, is confidential.

Confidential Information may be made available or obtained directly or indirectly, and before, on or after the date of this document.

Confidential Information does not include information that:

- (a) is in or enters the public domain through no fault of the receiving party or any of its officers, employees or agents;
- (b) is or was made available to the receiving party by a person (other than the disclosing party) who is not or was not then under an obligation of confidence to the disclosing party in relation to that information; or
- (c) is or was developed by the receiving party independently of the disclosing party and any of its officers, employees or agents.

**Construction Certificate** has the same meaning as in the Act.

**Contamination** has the meaning given to that word in the *Contaminated Land Management Act 1997* (NSW).

**Corporations Act** means the *Corporations Act 2001* (Cth).

**Dealing** means selling, transferring, assigning, novating, mortgaging, charging, or encumbering and, where appearing, **Deal** has the same meaning.

**Defect** means any error, omission, defect, non-conformity, discrepancy, shrinkage, blemish in appearance or other fault in the Public Benefits or any other matter which prevents the Public Benefits from complying with the terms of this document.

**Defects Liability Period** means in relation to the Public Benefits, the period of 12 months from the date on which the Developer's Works reach Completion.

**Developer's Representative** means the person named in Item 4 of Schedule 1 or his/her delegate.

**Developer's Works** means those parts of the Public Benefit described as "Developer's Works – O'Riordan Street" and "Developer's Works – Johnson Street" in clause 1 of Schedule 3, to be delivered by the Developer in accordance with this document.

**Developer's Works – Johnson Street** means those parts of the Public Benefit described as "Developer's Works – Johnson Street" in clause 1 of Schedule 3, to be delivered by the Developer in accordance with this document.

**Developer's Works – O'Riordan Street** means those parts of the Public Benefit described as "Developer's Works – O'Riordan Street", to be delivered by the Developer in accordance with this document.

**Development** means the development of the Land by the Developer described at Item 2 of Schedule 1.

**Development Application** means the development application identified in Item 5 of Schedule 1 and includes all plans, reports models, photomontages, material boards (as amended supplemented) submitted to the consent authority before the determination of that Development Application.

**Development Consent** means the consent granted to the Development Application for the Development and includes all modifications made under section 4.55 of the Act.

**Dispute** means any dispute or difference between the parties arising out of, relating to or in connection with this document, including any dispute or difference as to the formation, validity, existence or termination of this document.

**Environmental Laws** means all laws and legislation relating to environmental protection, building, planning, health, safety or work health and safety matters and includes the following:

- (a) the *Work Health and Safety Act 2011 (NSW)*;
- (b) the *Protection of the Environment Operations Act 1997 (NSW)*; and
- (c) the *Contaminated Land Management Act 1997 (NSW)*.

**Government Agency** means:

- (a) a government or government department or other body;



- (b) a governmental, semi-governmental or judicial person; or
- (c) a person (whether autonomous or not) who is charged with the administration of a law.

**Gross Floor Area** has the meaning given to that term in the *Sydney Local Environment Plan* in effect at the date of this document.

**GST** means the same as in the GST Act.

**GST Act** means *A New Tax System (Goods and Services Tax) Act 1999* (Cth).

**Guarantee** means an irrevocable unconditional bank guarantee or documentary performance bond for the Guarantee Amount which must:

- (a) be denominated in Australian dollars;
- (b) be an unconditional undertaking;
- (c) be signed and issued by a bank licensed to carry on business in Australia, an Australian Prudential Regulation Authority (APRA) regulated authorised deposit taking institution or an insurer authorised by APRA to conduct new or renewal insurance business in Australia having at all times an investment grade security rating from an industry recognised rating agency of at least:
  - (i) BBB + (Standard & Poors and Fitch);
  - (ii) Baa 1 (Moody's); or
  - (iii) Bbb (Bests);
- (d) be issued on behalf of the Developer;
- (e) have no expiry or end date;
- (f) state the beneficiary as the City;
- (g) be irrevocable;
- (h) state the Guarantee Amount as the minimum amount required by this document to be lodged as security;
- (i) state the purpose of the security as required in accordance with this document; and
- (j) be on such other terms approved by the City.

**Guarantee Amount(s)** means a Guarantee or Guarantees for the total amount listed in Item 6 of Schedule 1 of this document.

**Guarantee Amount(s) Due Date** means the date or milestone by which the Developer must provide the Guarantee Amount to the City, set out at Item 7 of Schedule 1.

**Index Number** means the Consumer Price Index (Sydney all groups) published by the Australian Bureau of Statistics from time to time.

**Insolvency Event** means:

- (a) having a controller, receiver, manager, administrator, provisional liquidator, liquidator or analogous person appointed;
- (b) an application being made to a court for an order to appoint a controller, provisional liquidator, trustee for creditors or in bankruptcy or analogous person to the person or any of the person's property
- (c) the person being taken under section 459F(1) of the Corporations Act to have failed to comply with a statutory demand;
- (d) an application being made to a court for an order for its winding up;
- (e) an order being made, or the person passing a resolution, for its winding up;
- (f) the person:
  - (i) suspending payment of its debts, ceasing (or threatening to cease) to carry on all or a material part of its business, stating that it is unable to pay its debts or being or becoming otherwise insolvent; or
  - (ii) being unable to pay its debts or otherwise insolvent;
- (g) the person taking any step toward entering into a compromise or arrangement with, or assignment for the benefit of, any of its members or creditors;
- (h) a court or other authority enforcing any judgment or order against the person for the payment of money or the recovery of any property; or
- (i) any analogous event under the laws of any applicable jurisdiction,

unless this takes place as part of a solvent reconstruction, amalgamation, merger or consolidation that has been approved by the other party.

**Land** means the land described in Item 1 of Schedule 1 of this document.

**Laws** means all applicable laws, regulations, industry codes and standards, including all Environmental Laws.

**Monetary Contribution** means that part of the Public Benefits described as "Monetary Contribution" in clause 1 of Schedule 3 to be paid by the Developer to the City in accordance with this document.

**Occupation Certificate** has the same meaning as in the Act.

**Personal Information** has the meaning set out in the *Privacy Act 1988* (Cth).

**Personnel** means the Developer's officers, employees, agents, contractors or subcontractors.

**Privacy Laws** means the *Privacy Act 1988* (Cth), the *Privacy and Personal Information Protection Act 1998* (NSW), the *Spam Act 2003* (Cth), the *Do Not Call Register Act 2006* (Cth) and any other applicable legislation, principles, industry codes and policies relating to the handling of Personal Information.

**Public Benefits** means the provision of benefits to the community by the Developer in the form and at the times specified in Schedule 3.

**Quantity Surveyor** means a qualified independent and practising quantity surveyor with at least five years' experience in the assessment of building and construction costs.

**Quantity Surveyor's Assessment** means the assessment by the Quantity Surveyor of the cost to deliver the Developer's Works or the Developer's Works – Johnson Street (as applicable).

**Regulation** means the *Environmental Planning and Assessment Regulation 2000* (NSW).

**Standards** means the policies, procedures and standards for carrying out the Developer's Works, listed at clause 6 of Schedule 3 and as amended by clauses 4.4(b) and 6(b) of Schedule 3.

**Subdivision of Land** has the same meaning as in the Act.

**Tax** means a tax, levy, duty, rate, charge, deduction or withholding, however it is described, that is imposed by law or by a Government Agency, together with any related interest, penalty, fine or other charge.

**Transfer Land** means land forming part of the Public Benefit that is to be either dedicated or transferred to the City in accordance with Schedule 3 of this document.

## 1.2 **Rules for interpreting this document**

Headings are for convenience only, and do not affect interpretation. The following rules also apply in interpreting this document, except where the context makes it clear that a rule is not intended to apply.

- (a) A reference to:
  - (i) a legislative provision or legislation (including subordinate legislation) is to that provision or legislation as amended, re-enacted or replaced, and includes any subordinate legislation issued under it;
  - (ii) a document (including this document) or agreement, or a provision of a document (including this document) or agreement, is to that

document, agreement or provision as amended, supplemented, replaced or novated;

- (iii) a party to this document or to any other document or agreement includes a permitted substitute or a permitted assign of that party;
  - (iv) a person includes any type of entity or body of persons, whether or not it is incorporated or has a separate legal identity, and any executor, administrator or successor in law of the person; and
  - (v) anything (including a right, obligation or concept) includes each part of it.
- (b) A singular word includes the plural, and vice versa.
  - (c) A word which suggests one gender includes the other genders.
  - (d) If a word or phrase is defined, any other grammatical form of that word or phrase has a corresponding meaning.
  - (e) If an example is given of anything (including a right, obligation or concept), such as by saying it includes something else, the example does not limit the scope of that thing.
  - (f) A reference to **including** means "including, without limitation".
  - (g) A reference to **dollars** or **\$** is to an amount in Australian currency.
  - (h) A reference to **this document** includes the agreement recorded by this document.
  - (i) Words defined in the GST Act have the same meaning in clauses about GST.
  - (j) This document is not to be interpreted against the interests of a party merely because that party proposed this document or some provision in it or because that party relies on a provision of this document to protect itself.

## 2. **APPLICATION OF THE ACT AND THE REGULATION**

### 2.1 **Application of this document**

This document is a planning agreement within the meaning of section 7.4 of the Act and applies to:

- (a) the Land; and
- (b) the Development.

### 2.2 **Public Benefits to be made by Developer**

Clause 5 and Schedule 3 set out the details of the:

- (a) Public Benefits to be delivered by the Developer;
- (b) time or times by which the Developer must deliver the Public Benefits; and

(c) manner in which the Developer must deliver the Public Benefits.

### 2.3 **Application of sections 7.11, 7.12 and 7.24 of the Act**

The application of sections 7.11, 7.12 and 7.24 of the Act are excluded to the extent set out in Items 5 and 6 of Schedule 2 to this document.

### 2.4 **City rights**

This document does not impose an obligation on the City to:

- (a) grant Development Consent for the Development; or
- (b) exercise any function under the Act in relation to a change to an environmental planning instrument, including the making or revocation of an environmental planning instrument.

### 2.5 **Explanatory note**

The explanatory note prepared in accordance with clause 25E of the Regulation must not be used to assist in construing this document.

## 3. **OPERATION OF THIS PLANNING AGREEMENT**

### 3.1 **Commencement**

This document will commence on the date of execution of this document by all parties to this document.

## 4. **WARRANTIES**

### 4.1 **Mutual warranties**

Each party represents and warrants that:

- (a) (**power**) it has full legal capacity and power to enter into this document and to carry out the transactions that it contemplates;
- (b) (**corporate authority**) it has taken all corporate action that is necessary or desirable to authorise its entry into this document and to carry out the transactions contemplated;
- (c) (**Authorisations**) it holds each Authorisation that is necessary or desirable to:
  - (i) enable it to properly execute this document and to carry out the transactions that it contemplates;
  - (ii) ensure that this document is legal, valid, binding and admissible in evidence; or
  - (iii) enable it to properly carry on its business as it is now being conducted, and it is complying with any conditions to which any of these Authorisations is subject;

- (d) (**documents effective**) this document constitutes its legal, valid and binding obligations, enforceable against it in accordance with its terms (except to the extent limited by equitable principles and laws affecting creditors' rights generally), subject to any necessary stamping or registration;
- (e) (**solvency**) there are no reasonable grounds to suspect that it will not be able to pay its debts as and when they become due and payable; and
- (f) (**no controller**) no controller is currently appointed in relation to any of its property, or any property of any of its subsidiaries.

#### 4.2 **Developer warranties**

- (a) The Developer warrants to the City that, at the date of this document:
  - (i) it is the registered proprietor of the Land;
  - (ii) it is legally entitled to obtain all consents and approvals that are required by this document and do all things necessary to give effect to this document;
  - (iii) all work performed by the Developer and the Personnel under this document will be performed with due care and skill and to a standard which is equal to or better than that which a well experienced person in the industry would expect to be provided by an organisation of the Developer's size and experience; and
  - (iv) it is not aware of any matter which may materially affect the Developer's ability to perform its obligations under this document.
- (b) The Developer warrants to the City that, prior to commencing delivery of the Public Benefits it will have obtained all Authorisations and insurances required under any Law to carry out its obligations under this document.

### 5. **PUBLIC BENEFITS**

#### 5.1 **Developer to provide Public Benefits**

The Developer must, at its cost and risk, provide the Public Benefits to the City in accordance with this document.

### 6. **COMPLETION**

#### 6.1 **Date of Completion**

The Developer must ensure that the Developer's Works reach Completion on or before the date or milestone referred to in clause 1 of Schedule 3 of this document.

#### 6.2 **Developer completion notice**

When, in the reasonable opinion of the Developer, the Developer's Works have reached Completion, the Developer must notify the City's Representative in writing and must include in that notice:

- (a) a statement from the person with direct responsibility and supervision of that work that in their opinion the Developer's Works have reached Completion;
- (b) copies of any warranties, guarantees, maintenance information or other material reasonably required for the City to assume responsibility for the Developer's Works; and
- (c) at least three sets of the "as built" drawings of the Developer's Works, including one set in electronic format,

**(Completion Notice).** For the avoidance of doubt, the Developer can issue separate Completion Notices at separate times for different elements of the Developer's Works, however the Developer must ensure that Completion is achieved for the Developer's Works before the due date specified in Item 1 of Schedule 3.

### 6.3 **Inspection by the City**

- (a) The City's Representative must inspect the Developer's Works within 5 Business Days of the date that the Completion Notice is received by the City. The City's Representative may refuse to complete the inspection until the Completion Notice has been issued with all required documentation attached in accordance with clause 6.2. Within 10 Business Days of the date of the inspection by the City's Representative, the City must by written notice to the Developer:
  - (i) state that Completion has been achieved;
  - (ii) state that Completion has not been achieved and, if so, identify the Defects, errors or omissions which, in the opinion of the City's Representative, prevent Completion; or
  - (iii) issue a notice under clause 6.4(a).
  - (iv) If the Developer disagrees with a notice from the City under cl. 6.3(a)(ii) stating that Completion has not been achieved, then that matter is to be determined in accordance with clause 11 (Dispute Resolution).
- (b) Nothing in this clause 6.3, or any notice issued under this clause 6.3, will:
  - (i) reduce or waive in any manner the Developer's responsibility to:
    - (A) deliver the Developer's Works in accordance with this document; or
    - (B) the Developer's responsibility to correct Defects, errors or omissions, whether or not these are identified by the City; or
  - (ii) create any liability for the City in relation to any defective aspect of the Developer's Works.

## 6.4 **Non-completion of Public Benefits**

- (a) If the Developer makes a request by notice in writing not to complete the Public Benefits (or any part of the Public Benefits):
  - (i) the City may permit the Developer not to complete the Public Benefits (or any part of the Public Benefits) by issuing a notice in writing to the Developer stating that completion of the items identified in that notice is not required to fulfil the Developer's obligations under this document; and
  - (ii) the City may make a claim on the Guarantee in such amount as is necessary to complete the portion of Public Benefit not being delivered by the Developer, such amount to be determined by agreement, or failing agreement, by a Quantity Surveyor to be jointly appointed by the parties.
- (b) If the Developer fails to complete the whole of the Public Benefits in the form and to the standards required under the Development Consent or this document then the City may either:
  - (i) complete the Public Benefits itself, including by exercising its right to compulsorily acquire the Transfer Land in accordance with clause 10.6 of this document; or
  - (ii) modify the Public Benefits to reasonably achieve the objectives identified in the Development Consent and this document,  
  
and may recover all costs of and reasonably incidental to that work from the Developer. The City can claim on the Guarantee in order to exercise this right, in which case the provisions of clause 10 will apply. To the extent that the City's costs exceed the amount of the Guarantee, the City can recover this amount from the Developer as a debt due and owing to the City.
- (c) If the City exercises its rights under this clause 6.4 to complete the Public Benefits, the Developer grants the City a licence for the period necessary for the City to access the Land to carry out, or procure the carrying out, of the Public Benefits.

## 7. **INDEMNITY**

The Developer indemnifies the City against all damage, expense, loss or liability of any nature suffered or incurred by the City arising from any act or omission by the Developer (or any Personnel) in connection with the performance of the Developer's obligations under this document, except where the damage, expense, loss or liability suffered or incurred is caused by, or contributed to by, any wilful or negligent act or omission of the City (or any person engaged by the City).

## 8. **DEFECTS LIABILITY**

### 8.1 **Security for Defects Liability Period**

Until the expiry of the relevant Defects Liability Period, the City may retain from the Guarantee an amount equal to 10% of the Attributed Value of the Developer's



Works as security for the Developer's performance of its obligations under this clause 8. The Developer must make any necessary arrangements to allow the provision of the Guarantee for the Defects Liability Period in accordance with this clause.

## 8.2 **Defect in the Public Benefits**

- (a) If:
  - (i) the Developer is in breach of clause 4.2 of this document; or
  - (ii) the City notifies the Developer of a Defect in the Public Benefits within the Defects Liability Period,then, following written notice from the City, the Developer must promptly correct or replace (at the Developer's expense) the defective elements of the Public Benefits.
- (b) If the Developer is unable or unwilling to comply with clause 8.2(a), or fails to rectify the Defect within three months of receiving notice from the City under clause 8.2(a), the City may:
  - (i) rectify the Defect itself;
  - (ii) make a claim on the Guarantee in accordance with clause 10 for the reasonable costs of the City in rectifying the Defect; and
  - (iii) to the extent the costs incurred to rectify the Defect exceeds the Guarantee, recover the reasonable costs from the Developer as a debt due and owing to the City.
- (c) If the City requires access to the Land to rectify any Defect, the Developer grants the City and its contractors a licence for such period as is necessary for the City and its contractors to access the Land to carry out, or procure the carrying out, of the rectification works.

## 9. **REGISTRATION AND CAVEAT**

### 9.1 **Registration of this document**

- (a) The Developer:
  - (i) consents to the registration of this document at the NSW Land Registry Services on the certificate of title to the Land;
  - (ii) warrants that it has obtained all consents to the registration of this document on the certificate of title to the Land; and
  - (iii) must within 10 Business Days of a written request from the City do all things necessary to allow the City to register this document on the certificate of title to the Land, including but not limited to:
    - (A) producing any documents or letters of consent required by the Registrar-General of the NSW Land Registry Services;

- (B) providing the production slip number when the Developer produces the certificate of title to the Land at the NSW Land Registry Services; and
  - (C) providing the City with a cheque for registration fees payable in relation to registration of this document at NSW Land Registry Services.
- (iv) The Developer must act promptly in complying with and assisting to respond to any requisitions raised by the NSW Land Registry Services that relate to registration of this document.

## 9.2 Release of this document

Once the Developer has provided all Public Benefits and otherwise complied with this document then the City must promptly do all things reasonably required to remove this document from the certificate of title to the Land.

## 10. ENFORCEMENT

### 10.1 Developer to provide Guarantee

The Developer must deliver the Guarantee for the Guarantee Amount to the City by the Guarantee Amount Due Date.

### 10.2 Adjustment of Guarantee Amount

On each anniversary of the date of the Guarantee (the "Adjustment Date"), the Guarantee Amounts are to be adjusted to a revised amount by applying the following formula:

$$\mathbf{RGA} = \mathbf{GA} \times (\mathbf{A/B})$$

where:

**RGA** is the revised guarantee amount applicable from the relevant Adjustment Date

**GA** is the Guarantee Amount that is current on the relevant Adjustment Date

**A** is the Index Number most recently published before the relevant Adjustment Date

**B** is the Index Number most recently published:

- (i) before the date of the Guarantee for the first Adjustment Date; and
- (ii) before the preceding Adjustment Date for every subsequent Adjustment Date

If after the formula is applied the revised Guarantee Amount will be less than the amount held at the preceding Adjustment Date, the Guarantee Amount will not be adjusted.

### 10.3 **Right of City to claim on Guarantee**

- (a) The Developer agrees that the City may make an appropriation from the Guarantee if:
- (i) the Developer fails to comply with clause 4.2 of Schedule 3 of this document (provision of concept design drawings and detailed costs estimate);
  - (ii) the Developer fails to comply with clause 4.3 of Schedule 3 of this document (provision of detailed design drawings and detailed costs estimate);
  - (iii) the Developer fails to comply with clause 2 of Schedule 3 (payment of Monetary Contribution);
  - (iv) the City allows the Developer not to complete the Public Benefits, or any part of them, in accordance with clause 6.4(a)(ii);
  - (v) an Insolvency Event occurs in respect of the Developer;
  - (vi) the Developer fails to deliver the Public Benefits in accordance with clause 6.4(b);
  - (vii) the Developer fails to rectify a Defect in accordance with clause 8.2 of this document;
  - (viii) the detailed designs for the Developer's Works are not finalised between the parties within 12 months of the date of issue of a Construction Certificate that approves the construction of any structures above the ground floor of the Development;
  - (ix) the Developer's Works do not reach Completion within 36 months of the date of issue of the first Construction Certificate in respect of the Development (or such later time as agreed by the City in writing); or
  - (x) the City incurs any other expense or liability in exercising its rights and powers under this document due to a breach of this document committed by the Developer.
- (b) Any amount of the Guarantee appropriated by the City in accordance with clause 10.3 must only be such amount as is required for, and must only be applied towards:
- (i) the costs and expenses incurred by the City rectifying any default by the Developer under this document; and
  - (ii) carrying out any works required to achieve the Public Benefits.

### 10.4 **Expenditure by the City**

If the City claims on the Guarantee to Complete the Developer's Works, then the City:

- (a) is not required to expend more money than the Guarantee Amount and may elect not to carry out items of the Developer's Works to ensure that those works can be carried out for an amount equal to or less than the Guarantee Amount; or
- (b) may expend more than the Guarantee Amount. If the City expends more money than the Guarantee Amount then the amount in excess of the Guarantee Amount will be deemed to be a debt due and owing to the City by the Developer, provided that the amount greater than the Guarantee Amount was required to complete the Developer's Works.

#### 10.5 **Top-up and return of Guarantee**

- (a) If the City calls upon the Guarantee in accordance with this clause 10 then the Developer must immediately provide to the City a replacement Guarantee to ensure that, at all times until the Guarantee is released in accordance with paragraph (b), the City is in possession of a Guarantee for a face value equivalent to the Guarantee Amount.

For the avoidance of doubt, in the case that the City only calls on part of the Guarantee, the Developer will be deemed to have complied with this clause by a top-up of the Guarantee to restore it to the full Guarantee Amount instead of a replacement Guarantee.

- (b) If:
  - (i) the monies secured by the Guarantee have not been expended;
  - (ii) the City has concurred with Completion in accordance with clause 6.3(a)(i) of this document, taking into account any approved non-completion of Public Benefits approved by clause 6.4(a) of this document; and
  - (iii) the City has been provided with the security for the Defects Liability Period in accordance with clause 8.1,

then the City will promptly return the Guarantee to the Developer following the issue of a notice pursuant to clause 6.3(a)(i) of this document.

- (c) If, following expiry of the Defects Liability Period, the City acting reasonably is satisfied that all defects have been rectified in accordance with clause 8 then the City must promptly return to the Developer the portion of the Guarantee retained by the City as security for the Defects Liability Period.

#### 10.6 **Compulsory acquisition**

If the Developer fails to transfer or dedicate the Transfer Land to the City in accordance with Schedule 3 of this document then the City may compulsorily acquire that land for the amount of \$1.00 in accordance with the *Land Acquisition (Just Terms Compensation) Act 1991 (NSW)*. The City and the Developer agree that:

- (a) this clause 10.6 is an agreement between the Developer and the City for the purposes of section 30 of the *Land Acquisition (Just Terms Compensation) Act 1991 (NSW)*;
- (b) in this clause 10.6 the Developer and the City have agreed on all relevant matters concerning the compulsory acquisition and the compensation to be paid for the acquisition; and
- (c) the Developer must pay the City, promptly on demand, an amount equivalent to all costs incurred by the City in acquiring the whole or any part of the Transfer Land as contemplated by this clause 10.6.

#### 10.7 **Addition**

At the Guarantee Amount Due Date the Guarantee Amount must be adjusted as follows:

**Guarantee Amount (to be provided) = Guarantee Amount plus A**

where:

**A** is the Attributed Value of the Developer's Works.

### 11. **DISPUTE RESOLUTION**

#### 11.1 **Application**

Any Dispute must be determined in accordance with the procedure in this clause 11.

#### 11.2 **Negotiation**

- (a) If any Dispute arises, a party to the Dispute (**Referring Party**) may by giving notice to the other party or parties to the Dispute (**Dispute Notice**) refer the Dispute to the Developer's Representative and the City's Representative for resolution. The Dispute Notice must:
  - (i) be in writing;
  - (ii) state that it is given pursuant to this clause 11; and
  - (iii) include or be accompanied by reasonable particulars of the Dispute including:
    - (A) a brief description of the circumstances in which the Dispute arose;
    - (B) references to any:
      - (aa) provisions of this document; and
      - (bb) acts or omissions of any person, relevant to the Dispute; and

- (C) where applicable, the amount in dispute (whether monetary or any other commodity) and if not precisely known, the best estimate available.
- (b) Within 10 Business Days of the Referring Party issuing the Dispute Notice (**Resolution Period**), the Developer's Representative and the City's Representative must meet at least once to attempt to resolve the Dispute.
- (c) The Developer's Representative and the City's Representative may meet more than once to resolve a Dispute. The Developer's Representative and the City's Representative may meet in person, via telephone, videoconference, internet-based instant messaging or any other agreed means of instantaneous communication to effect the meeting.

### 11.3 **Not use information**

The purpose of any exchange of information or documents or the making of any offer of settlement under this clause 11 is to attempt to settle the Dispute. Neither party may use any information or documents obtained through any dispute resolution process undertaken under this clause 11 for any purpose other than in an attempt to settle the Dispute.

### 11.4 **Condition precedent to litigation**

Subject to clause 11.5, a party must not commence legal proceedings in respect of a Dispute unless:

- (a) a Dispute Notice has been given; and
- (b) the Resolution Period has expired.

### 11.5 **Summary or urgent relief**

Nothing in this clause 11 will prevent a party from instituting proceedings to seek urgent injunctive, interlocutory or declaratory relief in respect of a Dispute.

## 12. **TAXES AND GST**

### 12.1 **Responsibility for Taxes**

- (a) The Developer is responsible for any and all Taxes and other like liabilities which may arise under any Commonwealth, State or Territory legislation (as amended from time to time) as a result of or in connection with this document or the Public Benefits.
- (b) The Developer must indemnify the City in relation to any claims, liabilities and costs (including penalties and interest) arising as a result of any Tax or other like liability for which the Developer is responsible under clause 12.1(a).

### 12.2 **GST free supply**

To the extent that Divisions 81 and 82 of the GST Law apply to a supply made under this document:

- (a) no additional amount will be payable by a party on account of GST; and
- (b) no tax invoices will be exchanged between the parties.

### 12.3 **Supply subject to GST**

To the extent that clause 12.2 does not apply to a supply made under this document, this clause 12.3 will apply.

- (a) If one party (**Supplying Party**) makes a taxable supply and the consideration for that supply does not expressly include GST, the party that is liable to provide the consideration (**Receiving Party**) must also pay an amount (**GST Amount**) equal to the GST payable in respect of that supply.
- (b) Subject to first receiving a tax invoice or adjustment note as appropriate, the receiving party must pay the GST amount when it is liable to provide the consideration.
- (c) If one party must indemnify or reimburse another party (**Payee**) for any loss or expense incurred by the Payee, the required payment does not include any amount which the Payee (or an entity that is in the same GST group as the Payee) is entitled to claim as an input tax credit, but will be increased under clause 12.3(a) if the payment is consideration for a taxable supply.
- (d) If an adjustment event arises in respect of a taxable supply made by a Supplying Party, the GST Amount payable by the Receiving Party under clause 12.3(a) will be recalculated to reflect the adjustment event and a payment will be made by the Receiving Party to the Supplying Party, or by the Supplying Party to the Receiving Party, as the case requires.
- (e) The Developer will assume the City is not entitled to any input tax credit when calculating any amounts payable under this clause 12.3.
- (f) In this document:
  - (i) consideration includes non-monetary consideration, in respect of which the parties must agree on a market value, acting reasonably; and
  - (ii) in addition to the meaning given in the GST Act, the term "GST" includes a notional liability for GST.

## 13. **DEALINGS**

### 13.1 **Dealing by the City**

- (a) The City may Deal with its interest in this document without the consent of the Developer if the Dealing is with a Government Agency. The City must give the Developer notice of the Dealing within five Business Days of the date of the Dealing.

- (b) The City may not otherwise Deal with its interest in this document without the consent of the Developer, such consent not to be unreasonably withheld or delayed.

### 13.2 **Dealing by the Developer**

- (a) Prior to registration of this document in accordance with clause 9, the Developer must not Deal with this document or the Land without:
  - (i) the prior written consent of the City, with such consent not to be unreasonably withheld; and
  - (ii) the City, the Developer and the third party the subject of the Dealing entering into a deed of consent to the Dealing on terms acceptable to the City.
- (b) On and from registration of this document in accordance with clause 9:
  - (i) the Developer may Deal with this document without the consent of the City only as a result of the sale of the whole of the Land (without subdivision) to a purchaser of the Land;
  - (ii) the Developer may register a plan of strata subdivision, and the City consents to this document remaining registered only on the certificate of title to the common property of the strata plan upon registration of the strata plan; and
  - (iii) the Developer must not otherwise Deal with this document to a third party that is not a purchaser of the whole or any part of the Land without:
    - (A) the prior written consent of the City, with such consent not to be unreasonably withheld; and
    - (B) the City, the Developer and the third party the subject of the Dealing entering into a deed of consent to the Dealing on terms acceptable to the City.

The Developer must pay the City's costs and expenses relating to any consent or documentation required due to the operation of this clause 13.3.

### 13.3 **Extinguishment or creation of interests on Transfer Land**

- (a) Prior to the dedication or transfer of the Transfer Land to the City, the Developer must:
  - (i) extinguish all leases and licences over the Transfer Land; and
  - (ii) use its best endeavours to extinguish all redundant encumbrances and those that, in the City's opinion, would unreasonably impede the intended use of all or any part of the Transfer Land.
- (b) The Developer must comply with any directions by the City relating to the Transfer Land which are reasonably necessary for the proper development



and intended use of the Transfer Land, including but not limited to the creation of any encumbrances over the Transfer Land.

#### 14. **TERMINATION**

- (a) The City may terminate this document by notice in writing to the Developer if the Development Consent lapses or is surrendered by the Developer.
- (b) If the City terminates this document then:
  - (i) the rights of each party that arose before the termination or which may arise at any future time for any breach or non-observance of obligations occurring prior to the termination are not affected;
  - (ii) the Developer must take all steps reasonably necessary to minimise any loss the each party may suffer as a result of the termination of this document;
  - (iii) the City will return the Guarantee to the Developer after first deducting any amounts owing to the City or costs incurred by the City by operation of this document. If in exercising its rights under this document the City expends more money than the Guarantee Amount then the amount in excess of the Guarantee Amount will be deemed to be a debt due and owing to the City by the Developer; and
  - (iv) the City will, at the Developer's cost, do all things reasonably required to remove this document from the certificate of title to the Land.

#### 15. **CONFIDENTIALITY AND DISCLOSURES**

##### 15.1 **Use and disclosure of Confidential Information**

A party (**receiving party**) which acquires Confidential Information of another party (**disclosing party**) must not:

- (a) use any of the Confidential Information except to the extent necessary to exercise its rights and perform its obligations under this document; or
- (b) disclose any of the Confidential Information except in accordance with clauses 15.2 or 15.3.

##### 15.2 **Disclosures to personnel and advisers**

- (a) The receiving party may disclose Confidential Information to an officer, employee, agent, contractor, or legal, financial or other professional adviser if:
  - (i) the disclosure is necessary to enable the receiving party to perform its obligations or to exercise its rights under this document; and
  - (ii) prior to disclosure, the receiving party informs the person of the receiving party's obligations in relation to the Confidential Information

under this document and obtains an undertaking from the person to comply with those obligations.

- (b) The receiving party:
  - (i) must ensure that any person to whom Confidential Information is disclosed under clause 15.2(a) keeps the Confidential Information confidential and does not use it for any purpose other than as permitted under clause 15.2(a); and
  - (ii) is liable for the actions of any officer, employee, agent, contractor or legal, financial or other professional adviser that causes a breach of the obligations set out in clause 15.2(b)(i).

### 15.3 **Disclosures required by law**

- (a) Subject to clause 15.3(b), the receiving party may disclose Confidential Information that the receiving party is required to disclose:
  - (i) by law or by order of any court or tribunal of competent jurisdiction; or
  - (ii) by any Government Agency, stock exchange or other regulatory body.
- (b) If the receiving party is required to make a disclosure under clause 15.3(a), the receiving party must:
  - (i) to the extent possible, notify the disclosing party immediately it anticipates that it may be required to disclose any of the Confidential Information;
  - (ii) consult with and follow any reasonable directions from the disclosing party to minimise disclosure; and
  - (iii) if disclosure cannot be avoided:
    - (A) only disclose Confidential Information to the extent necessary to comply; and
    - (B) use reasonable efforts to ensure that any Confidential Information disclosed is kept confidential.

### 15.4 **Receiving party's return or destruction of documents**

On termination of this document the receiving party must immediately:

- (a) deliver to the disclosing party all documents and other materials containing, recording or referring to Confidential Information; and
- (b) erase or destroy in another way all electronic and other intangible records containing, recording or referring to Confidential Information,

which are in the possession, power or control of the receiving party or of any person to whom the receiving party has given access.

## 15.5 **Security and control**

The receiving party must:

- (a) keep effective control of the Confidential Information; and
- (b) ensure that the Confidential Information is kept secure from theft, loss, damage or unauthorised access or alteration.

## 15.6 **Media releases**

The Developer must not issue any information, publication, document or article for publication in any media concerning this document or the Public Benefits without the City's prior written consent.

## 16. **NOTICES**

- (a) A notice, consent or other communication under this document is only effective if it is in writing, signed and either left at the addressee's address or sent to the addressee by mail or fax. If it is sent by mail, it is taken to have been received 5 Business Days after it is posted. If it is sent by fax, it is taken to have been received when the addressee actually receives it in full and in legible form.
- (b) A person's address and fax number are those set out in Schedule 1 for the City's Representative and the Developer's Representative, or as the person notifies the sender in writing from time to time.

## 17. **GENERAL**

### 17.1 **Governing law**

- (a) This document is governed by the laws of New South Wales.
- (b) Each party submits to the exclusive jurisdiction of the courts exercising jurisdiction in New South Wales, and any court that may hear appeals from any of those courts, for any proceedings in connection with this document, and waives any right it might have to claim that those courts are an inconvenient forum.

### 17.2 **Access to information**

In accordance with section 121 of the *Government Information (Public Access) Act 2009 (NSW)*, the Developer agrees to allow the City immediate access to the following information contained in records held by the Developer:

- (a) information that relates directly to the delivery of the Public Benefits by the Developer;
- (b) information collected by the Developer from members of the public to whom the Developer provides, or offers to provide, services on behalf of the City; and

- (c) information received by the Developer from the City to enable the Developer to deliver the Public Benefits.

**17.3 Liability for expenses**

- (a) The Developer must pay its own and the City's expenses incurred in negotiating, executing, registering, releasing, administering and enforcing this document.
- (b) The Developer must pay for all reasonable costs and expenses associated with the preparation and giving of public notice of this document and the explanatory note prepared in accordance with the Regulations and for any consent the City is required to provide under this document.

**17.4 Relationship of parties**

- (a) Nothing in this document creates a joint venture, partnership, or the relationship of principal and agent, or employee and employer between the parties; and
- (b) No party has the authority to bind any other party by any representation, declaration or admission, or to make any contract or commitment on behalf of any other party or to pledge any other party's credit.

**17.5 Giving effect to this document**

Each party must do anything (including execute any document), and must ensure that its employees and agents do anything (including execute any document), that the other party may reasonably require to give full effect to this document.

**17.6 Time for doing acts**

- (a) If:
  - (i) the time for doing any act or thing required to be done; or
  - (ii) a notice period specified in this document,expires on a day other than a Business Day, the time for doing that act or thing or the expiration of that notice period is extended until the following Business Day.
- (b) If any act or thing required to be done is done after 5pm on the specified day, it is taken to have been done on the following Business Day.

**17.7 Severance**

If any clause or part of any clause is in any way unenforceable, invalid or illegal, it is to be read down so as to be enforceable, valid and legal. If this is not possible, the clause (or where possible, the offending part) is to be severed from this document without affecting the enforceability, validity or legality of the remaining clauses (or parts of those clauses) which will continue in full force and effect.

#### 17.8 **Preservation of existing rights**

The expiration or termination of this document does not affect any right that has accrued to a party before the expiration or termination date.

#### 17.9 **No merger**

Any right or obligation of any party that is expressed to operate or have effect on or after the completion, expiration or termination of this document for any reason, will not merge on the occurrence of that event but will remain in full force and effect.

#### 17.10 **Waiver of rights**

A right may only be waived in writing, signed by the party giving the waiver, and:

- (a) no other conduct of a party (including a failure to exercise, or delay in exercising, the right) operates as a waiver of the right or otherwise prevents the exercise of the right;
- (b) a waiver of a right on one or more occasions does not operate as a waiver of that right if it arises again; and
- (c) the exercise of a right does not prevent any further exercise of that right or of any other right.

#### 17.11 **Operation of this document**

- (a) This document contains the entire agreement between the parties about its subject matter. Any previous understanding, agreement, representation or warranty relating to that subject matter is replaced by this document and has no further effect.
- (b) Any right that a person may have under this document is in addition to, and does not replace or limit, any other right that the person may have.
- (c) Any provision of this document which is unenforceable or partly unenforceable is, where possible, to be severed to the extent necessary to make this document enforceable, unless this would materially change the intended effect of this document.

#### 17.12 **Operation of indemnities**

- (a) Each indemnity in this document survives the expiry or termination of this document.

#### 17.13 **Inconsistency with other documents**

Unless the contrary intention is expressed, if there is an inconsistency between any of one or more of:

- (a) this document;
- (b) any Schedule to this document; and

(c) the provisions of any other document of the Developer,

the order of precedence between them will be the order listed above, this document having the highest level of precedence.

**17.14 No fetter**

Nothing in this document in any way restricts or otherwise affects the City's unfettered discretion to exercise its statutory powers as a public authority.

**17.15 Counterparts**

This document may be executed in counterparts.

## SCHEDULE 1

### Agreement Details

ITEM	TERM	DESCRIPTION
1.	<b>Land</b>	Lot 1 DP 1004389, being 22 O'Riordan Street, Alexandria NSW 2015
2.	<b>Development</b>	<p>Concept Development Application for a building envelope and basement levels with indicative commercial uses and vehicular access from Johnson Street, at 22 O'Riordan Street, Alexandria NSW 2015, and development of the Land as subsequently approved by further detailed/staged development consents related to the Development Consent.</p> <p>The total Gross Floor Area of the Development on the Land is 18,590 square metres subject to any additional area awarded through design excellence and end of trip facilities.</p>
3.	<b>City's Representative</b>	<p>Name: Director, Planning, Development and Transport</p> <p>Address: Level 1, 456 Kent Street, Sydney NSW 2000</p> <p>Email address: <a href="mailto:applications@cityofsydney.nsw.gov.au">applications@cityofsydney.nsw.gov.au</a></p>
4.	<b>Developer's Representative</b>	<p>Name: Cameron Habler</p> <p>Address: Level 9, Challis House, 4 Martin Place Sydney NSW 2000</p> <p>Email address: <a href="mailto:c.habler@markham.com.au">c.habler@markham.com.au</a></p>
5.	<b>Development Application</b>	D/2019/686
6.	<b>Guarantee Amount</b>	A total amount of the Attributed Values of the Developer's Works
7.	<b>Guarantee Amount Due Date</b>	Prior to the issue of the first Construction Certificate for the Development.

## SCHEDULE 2

### Requirements under the Act and Regulation (clause 2)

The below table summarises how this document complies with the Act and Regulation.

ITEM	SECTION OF ACT OR REGULATION	PROVISION/CLAUSE OF THIS DOCUMENT
1.	<p><b>Planning instrument and/or development application</b> (section 7.4(1) of the Act)</p> <p>The Developer has:</p> <p>(a) sought a change to an environmental planning instrument;</p> <p>(b) made, or proposes to make, a Development Application; or</p> <p>(c) entered into an agreement with, or is otherwise associated with, a person, to whom paragraph (a) or (b) applies.</p>	<p>(a) No</p> <p>(b) Yes</p> <p>(c) No</p>
2.	<p><b>Description of land to which this document applies</b> (section 7.4(3)(a) of the Act)</p>	Item 1 of Schedule 1.
3.	<p><b>Description of change to the environmental planning instrument to which this document applies and/or the development to which this document applies</b> (section 7.4(3)(b) of the Act)</p>	The Development as described in clause 2.1.
4.	<p><b>The nature and extent of the provision to be made by the developer under this document, the time or times by which the provision is to be made and the manner in which the provision is to be made</b> (section 7.4(3)(c) of the Act)</p>	Schedule 3 and Annexure A.
5.	<p><b>Whether this document excludes (wholly or in part) of does not exclude the application of section 7.11, 7.12 or 7.24 to the development</b> (section 7.4(3)(d) of the Act)</p>	<p>Section 7.11 not excluded</p> <p>Section 7.12 not excluded</p> <p>Section 7.24 excluded</p>



ITEM	SECTION OF ACT OR REGULATION	PROVISION/CLAUSE OF THIS DOCUMENT
6.	<b>Applicability of section 7.11 of the Act</b> (section 7.4(3)(e) of the Act)	The application of section 7.11 of the Act is not excluded in respect of the Development and contributions (if any) under section 7.11 will be required to be paid.
7.	<b>Consideration of benefits under this document if section 7.11 applies</b> (section 7.4(3)(e) of the Act)	Benefits <b>are not</b> to be taken into consideration in determining a development contribution under section 7.11 of the Act.
8.	<b>Mechanism for Dispute Resolution</b> (section 7.4(3)(f) of the Act)	Clause 11
9.	<b>Enforcement of this document</b> (section 7.4(3)(g) of the Act)	Clause 10
10.	<b>No obligation to grant consent or exercise functions</b> (section 7.4(9) of the Act)	Clause 2.4
11.	<b>Registration of this document</b> (section 7.6 of the Act)	Clause 9
12.	<b>Whether certain requirements of this document must be complied with before a construction certificate is issued</b> (clause 25E(2)(g) of the Regulation)	Provision to the City of the Guarantee; and Provision to the City of the Monetary Contribution.
13.	<b>Whether certain requirements of this document must be complied with before a subdivision certificate is issued</b> (clause 25E(2)(g) of the Regulation)	Not applicable
14.	<b>Whether certain requirements of this document must be complied with before an occupation certificate is issued</b> (clause 25E(2)(g) of the Regulation)	Transfer of the Transfer Land to the City; and Completion of the Developer's Works.
15.	<b>Whether the explanatory note that accompanied exhibition of this document may be used to assist in construing this document</b> (clause 25E(7) of the Regulation)	Clause 2.5

### SCHEDULE 3

#### Public Benefits (clause 5)

1. **PUBLIC BENEFITS - OVERVIEW**

The Developer must provide the Public Benefits in accordance with Schedule 3 and this document. The Attributed Value, timing of delivery and additional specifications relating to the Public Benefits is set out in the table below

	<b>Public Benefit</b>	<b>Attributed Value</b>	<b>Due date</b>	<b>Additional specifications</b>
1.	Monetary Contribution	\$1,487,000 (minus the deductions for the Transfer Land and the Developer's Works under clause 2.3 of Schedule 3)	Prior to the issue of the first Construction Certificate for the Development.	Not applicable
2.	Transfer Land	\$176,800	After Completion but before the issue of the first or any Occupation Certificate for the Development.	An area of not less than 884 square metres unless otherwise agreed by the City. Plans showing the indicative location of the Transfer Land are contained in Annexure A to this document.
3A.	Developer's Works – O'Riordan Street	\$72,038	Prior to the first or any Occupation Certificate for the Development.	Plans and specifications showing the nature and extent of the required Developer's Works – O'Riordan Street as at the date of this document are contained in Annexure A to this document. New widened concrete footpath to be constructed adjacent to O'Riordan Street in the locations specified in the plans and specifications in Annexure A, in

				accordance with the City's technical specifications.
3B.	Developer's Works – Johnson Street	As determined under cl. 4.3 of this Schedule 3.	Prior to the first or any Occupation Certificate for the Development.	Plans and specifications showing the nature and extent of the required Developer's Works – Johnson Street as determined under clause 4.2(h) are not yet resolved, except for the locations of the works. The detailed design will be resolved as determined under clause 4.3, however is to include new widened concrete footpath to be constructed and associated landscaping to be undertaken adjacent to Johnson Street in the locations specified in the plans in Annexure A, in accordance with the City's technical specifications.

## 2. PAYMENT OF MONETARY CONTRIBUTION

### 2.1 Payment

Subject to clauses 2.2, 2.3, 2.4 and 4.3, the Developer must pay the Monetary Contribution to the City prior to the issue of the first Construction Certificate for the Development in cash or by unendorsed bank cheque.

### 2.2 Indexation

If the Monetary Contribution is not paid to the City on the date of this document then at the date of payment the Monetary Contribution must be indexed as follows:

**Monetary Contribution (to be provided) =**

**Monetary Contribution (as per item 1 of clause 1 above)                    x**  
**(A/B)**

where:

**A** is the Index Number most recently published before the date the Monetary Contribution is to be paid

**B** is the Index Number most recently published before the date this agreement commenced in accordance with clause 0 of this document.

If after the formula is applied the Monetary Contribution will be less than the amount stated in item 1 of clause 1 above, the Monetary Contribution will not be adjusted.

### 2.3 **Deductions**

At the date of payment specified in clause 2.1 the Monetary Contribution must be adjusted as follows:

**Monetary Contribution (to be provided) =**

**Monetary Contribution (as per item 1 of clause 1 above as indexed pursuant to clause 2.2) less (A + B + C)**

where:

**A** is the Attributed Value of the Developer's Works – Johnson Street.

**B** is the Attributed Value of the Developer's Works – O'Riordan Street.

**C** is the Attributed Value of the Transfer Land.

### 2.4 **No trust**

Nothing in this document creates any form of trust arrangement or fiduciary duty between the City and the Developer. Following receipt of the Monetary Contribution, the City is not required to separately account for the Monetary Contribution, report to the Developer regarding expenditure of the Monetary Contribution or comply with any request by the Developer to trace the Monetary Contribution.

## 3. **TRANSFER LAND**

### 3.1 **Dedication of land – decision**

The Developer must, at its cost, take all steps required to transfer the Transfer Land to the City by the due date specified in clause 1 of Schedule 3. As part of this obligation, the Developer must confirm with the City whether the Transfer Land is to be:

- (a) dedicated to the City on registration of a plan of subdivision; or
- (b) transferred to the City on registration of a transfer instrument.

### 3.2 **Obligations on dedication**

The requirement for the Developer to dedicate the Transfer Land to the City is satisfied where a deposited plan is registered in the register of plans held with the Registrar-General that dedicates land as a public road (including a temporary public road) under the *Roads Act 1993* (NSW) or creates a public reserve or drainage reserve under the *Local Government Act 1993* (NSW).

### 3.3 **Obligations on transfer**

- (a) The requirement for the Developer to transfer the Transfer Land to the City is satisfied where:
  - (i) the City is given:
    - (A) an instrument in registrable form under the *Real Property Act 1900* (NSW) duly executed by the Developer as transferor that is effective to transfer the title to the Transfer Land to the City when executed by the City as transferee and registered;
    - (B) the written consent to the registration of the transfer of any person whose consent is required to that registration; and
    - (C) a written undertaking from any person holding the certificate of title to the production of the certificate of title for the purposes of registration of the transfer.
- (b) The Developer is to do all things reasonably necessary to enable registration of the instrument of transfer to occur.
- (c) The Developer must ensure that the Transfer Land is:
  - (i) free of all encumbrances and affectations (whether registered or unregistered and including without limitation any charge or liability for rates, taxes and charges) except for any encumbrances agreed in writing by the City in its absolute discretion; and
  - (ii) remediated in accordance with the Development Consent.
- (d) The Developer must indemnify and agree to keep indemnified the City against all claims made against the City as a result of any Contamination in, over, under or migrating from the whole or any part of the Transfer Land but only in relation to Contamination that existed on or before the date that the Transfer Land is dedicated to the City in accordance with the requirements of this clause.
- (e) The Developer warrants that as at the date of this deed the Transfer Land is not subject to any Adverse Affectation and warrants as to those matters in Schedule 3 of the *Conveyancing (Sale of Land) Regulation 2010* (NSW), unless otherwise notified to and agreed by the City in writing in its absolute discretion.

## 4. **FINAL DESIGN OF THE DEVELOPER'S WORKS**

### 4.1 **Scope of Developer's Works**

Subject to clauses 4.2 and 4.3, as at the date of this document, the nature and extent of the required Developer's Works is set out in Annexure A to this document. The parties agree that further design refinement of the Developer's Works may be necessary, having regard to:

- (a) the extent to which the design of the Developer's Works has been approved by the City;
- (b) conditions affecting the Developer's Works that were not reasonably capable of identification prior to the date of this document;
- (c) the extent of any refinement of the design of the Developer's Works permitted by this clause 4 of Schedule 3;
- (d) any modification to the Development Consent made and approved under section 4.55 of the Act or any other development consent granted that relates to the Developer's Works; and
- (e) the reasonable requirements of the City, including in regard to the Standards.

#### 4.2 **Developer's Works – Johnson Street**

- (a) The parties acknowledge and agree that at the date of this document:
  - (i) the concept design of the Developer's Works – Johnson Street has not been determined; and
  - (ii) the Attributed Value for the Developer's Works – Johnson Street has not been determined.
- (a) After the issue of the Concept Development Consent for the Development but prior to the Developer submitting the development application for the first Detailed/Staged Development Consent which relates to the Development, the Developer must submit to the City's Representative for approval concept design drawings of the Developer's Works – Johnson Street.
- (b) Within 20 Business Days after the City's Representative has received the concept design drawings, the City will inform the Developer in writing as to whether the concept design drawings are approved, with such approval not to be unreasonably withheld. If the concept design drawings are not approved, the City will inform the Developer in writing of what further information or modifications are required and the Developer will have a further 10 Business Days to re-submit the required information, following which the process outlined in this paragraph 4.2(a) will apply again.
- (c) If the Developer:
  - (i) fails to prepare the concept design drawings; or
  - (ii) does not provide further information or modify the concept design drawings,

in accordance with this clause 4.2 of Schedule 3, then the City may exercise its rights under clause 10 of this document in order to carry out the Developer's Works – Johnson Street itself at the cost of the Developer.

- (d) The concept design drawings for the Developer's Works – Johnson Street approved by the City under this clause 4.2 of Schedule 3 are taken to have been the plans and specifications for the Developer's Works – Johnson Street annexed to this agreement at Annexure A for the purposes of this document.

**4.3 Final design of Developer's Works and Attributed Value of Developer's Works – Johnson Street**

- (a) After the Developer submits the development application for the first detailed/Staged Development Consent in relation to the Development, but prior to the issue of the first Construction Certificate for the Development, the Developer must submit to the City's Representative for approval:
  - (i) detailed design drawings of the Developer's Works that reflect the plans and specifications set out in Annexure A; and
  - (ii) a detailed costs estimate (certified by a Quantity Surveyor) setting out the estimated cost of the Developer's Works – Johnson Street.
- (b) Within 20 Business Days after the City's Representative has received the detailed design drawings and detailed costs estimate, the City will inform the Developer in writing as to whether the detailed design drawings and costs estimate are approved, such approval not to be unreasonably withheld. If the detailed design drawings or costs estimate are not approved, the City will inform the Developer in writing of what further information or modifications are required and the Developer will have a further 10 Business Days to re-submit the required information, following which the process outlined in this paragraph (b) will apply again.
- (c) Regarding the costs estimate, the Developer agrees that the City may:
  - (i) reject items included within the Quantity Surveyor's Assessment which are not directly related to the Developer's Works;
  - (ii) require substantiation for the costs of items where the amount estimated is considered by the City to be excessive;
  - (iii) require an adjustment to the costs estimate to reflect a variation to the design required under this clause 4.24.3 of Schedule 3.
- (d) If the Developer:
  - (i) fails to prepare the detailed design drawings or detailed costs estimate; or
  - (ii) does not provide further information or modify the detailed design drawings or detailed costs estimate,

in accordance with this clause 4.3 of Schedule 3, then the City may exercise its rights under clause 10 of this document in order to carry out the Developer's Works itself at the cost of the Developer.

- (e) The costs of the Developer's Works – Johnson Street set out in the detailed costs estimates for the Developer's Works – Johnson Street approved by the

City under this clause 4.3 of Schedule 3 are to be the Attributed Value of the Developer's Works – Johnson Street for the purposes of this document. The parties agree that the Attributed Value of the Developer's Works – Johnson Street will be:

- (i) deducted from the Monetary Contribution in accordance with clause 2.3 prior to payment; and
  - (ii) added to the Guarantee Amount in accordance with clause 10.7 before the Guarantee Amount Due Date.
- (f) The Developer agrees that the value of the Developer's Works may be adjusted following completion of the process set out in this clause 4.3 of Schedule 3 and accordingly the Monetary Contribution would be adjusted in accordance with the formula in clause 2.3 if this occurred. The Developer acknowledges that the scope of the Developer's Works will not change or reduce if the costs required to complete those works is greater than the amount estimated at the date of this document.

#### 4.4 **Preparation of and changes to construction design drawings**

- (a) Following approval of the detailed design drawings by the City in accordance with clause 4.3 of Schedule 3, the Developer must promptly:
  - (i) prepare construction design drawings that comply with the detailed design drawings; and
  - (ii) provide the City with a copy of the construction design drawings.
- (b) Subject to clause 4.4(c) of Schedule 3, the City, acting reasonably, may by written notice to the Developer at any time, approve, vary or direct the Developer to vary the construction design drawings so that the Developer's Works reflect:
  - (i) the Standards;
  - (ii) a departure or discrepancy from the plans approved under clause 4.3 of Schedule 3; or
  - (iii) any other standard or specification for materials or methodology for carrying out works that is adopted by the City from time to time, provided that any direction given under this clause 4.4(b)(iii) of Schedule 3 does not significantly increase:
    - (A) the cost of that element of the Developer's Works; or
    - (B) the complexity of implementation of the Developer's Works that may lead to a significant delay in the completion of the Developer's Works.
- (c) After the City approves the detailed design drawings of the Developer's Works under clause 4.3, the City may only add to, vary or remove a standard to the Standards under clause 4.4(b) if the amendment to the Standards is required:



- (i) by Law;
  - (ii) to reflect a change in Laws; or
  - (iii) to reflect a change in industry standards.
- (d) Within 20 Business Days of receiving a notice from the City under clause 4.4(b) of Schedule 3, the Developer must:
- (i) to the extent practicable, use reasonable endeavours to comply with the notice given by the City; or
  - (ii) if the Developer determines that the notice given by the City is unreasonable or impracticable, notify a dispute in accordance with clause 11 of this document.

If the Developer does not provide any response during the 20 Business Days after receiving a notice from the City under clause 4.4(b) of Schedule 3, it is deemed that the Developer accepts the notice given by the City and will take all steps required to comply with the notice.

- (e) The City does not assume or owe any duty of care to the Developer in reviewing any design drawings submitted to it under this clause 4.4 of Schedule 3 or for any errors, omissions or non-compliance with this document.
- (f) No participation by the City in the development of, the review of, or comments on any design drawings submitted by the Developer will lessen or otherwise affect the Developer's obligations under this document or constitute an acknowledgement by the City that the Developer has complied with its obligations under this document.

## 5. **CONSTRUCTION OF DEVELOPER'S WORKS**

### 5.1 **Insurance**

- (a) From commencement of the Developer's Works until expiration of the Defects Liability Period, the Developer must effect and maintain (or cause to be effected and maintained under one or more policies of insurance and without requiring any risk to be double insured) the following insurances held with an insurer licensed by the Australian Prudential Regulation Authority or holding an investment grade rating from Standard & Poors, Moody's or Fitch:
  - (i) worker's compensation insurance or registrations as required by Laws;
  - (ii) public liability insurance written on an occurrence basis with a limit of indemnity of not less than \$20,000,000 covering all aspects of the Developer's Works;
  - (iii) construction works insurance in relation to the Developer's Works; and

- (iv) motor vehicle third party cover with a limit of indemnity of not less than \$20 million for each and every occurrence.
- (b) The Developer must submit a copy of all certificates of insurance to the City:
  - (i) prior to commencing construction of the Developer's Works; and
  - (ii) promptly following a written request by the City, provided that such a request is not made more than twice in any 12 month period.

## 5.2 **Approvals and consents**

The Developer must, at its cost, obtain all relevant approvals and consents for the Developer's Works, whether from the City or from any other relevant Government Agency, including any necessary road opening permits. Before commencing the Developer's Works, the Developer must give to the City copies of all approvals and consents for the Developer's Works, other than the Development Consent.

## 5.3 **Construction work**

The Developer must, at its cost:

- (a) carry out and complete the Developer's Works in accordance with all approvals and consents relating to the Developer's Works, including any approval given by the City under this document;
- (b) ensure that all Developer's Works are constructed in a good and workmanlike manner, in accordance with the plans approved under this document so that the Developer's Works are structurally sound, fit for purpose and suitable for their intended use;
- (c) ensure that the Developer's Works are Complete by the due date specified in clause 1 of Schedule 3 and promptly after becoming aware advise the City's Representative of any significant delays in completing the Developer's Works or delays that may impact the delivery of the Public Benefits by the due date specified in Item 1 of Schedule 3; and
- (d) comply with all reasonable directions of the City in respect to construction of the Developer's Works.

## 5.4 **Inspections by the City**

The City, as a party to this document and not in its role as a Government Agency, may:

- (a) inspect the Developer's Works during the course of construction at reasonable times and on reasonable notice; and

- (b) notify the Developer's Representative of any material or significant defect, error or omission relating to the construction or installation of the Developer's Works identified during or as the result of an inspection.

Any failure by the City to identify a Defect, error or omission will not be construed as amounting to an acceptance by the City of the Defect, error or omission.

## 6. **STANDARDS**

- (a) The Standards listed in this clause are included for information purposes only, and as a guide to the relevant standards for the general nature of the work identified as Developer's Works in this document as at the date of this document.
- (b) Subject to clause 6(c), the City may add to, vary or remove a standard to the Standards by written notice to the Developer.
- (c) The City may only add to, vary or remove a standard to the Standards under clause 6(b) prior to the date on which the City approves the detailed design drawings of the Developer's Works under clause 4.3.
- (d) The City makes no representation or warranty as to the currency of the Standards listed in this clause, or their application on the final design of the Developer's Works. The Developer must make its own enquiries regarding whether any standard has been replaced or supplemented.
- (e) In the event that an Australian Standard prescribed a different level of material, finish, work or workmanship than those contained in a City Standard, then the higher of the two standards will apply.
- (f) If there is a conflict between City Standards then the Developer must request the City nominate the correct and applicable City Standard. The City's decision as to the applicable Standard is final.

### **Relevant Australian Standards – Verge Works, Through site links**

- AS 1725 Geotechnical Site investigations
- AS 4455 Masonry Units and segmental pavers
- AS 4678 Earth Retaining Structures
- AS 3600 Concrete Structures
- AS 2876 Concrete kerbs and channels
- AS 1158 Road Lighting
- AS 1743 Road signs
- AS 4282 Control of the Obtrusive Effects of Outdoor lighting
- AS 3500 Plumbing and Drainage
- AS 3700 Masonry Structures

- AS 2890 Parking Facilities
- AS 1428 Design for Access and Mobility
- AS 4454 Composts, soil conditioners and mulches

**Relevant Australian Standards – Roads (including pedestrian areas)**

- AS 1725 Geotechnical Site investigations
- AS 4455 Masonry Units and segmental pavers
- AS 4678 Earth Retaining Structures
- AS 3600 Concrete Structures
- AS 2876 Concrete kerbs and channels
- AS 1158 Road Lighting
- AS 4282 Control of the Obtrusive Effects of Outdoor lighting
- AS 1428 Design for Access and Mobility
- AS 3500 Plumbing and Drainage
- AS 3700 Masonry Structures
- AS 2890 Parking Facilities
- AS 1742 Manual of uniform traffic control devices
- AS 1743 Road Signs

**City Standards (All Works)**

- City of Sydney Contaminated Lands DCP 2004
- Sydney Street Code 2013
- Sydney Lights Code 2013
- City of Sydney Access Policy
- Sydney Street Technical Specification and Drawings
- City of Sydney Street Tree Master Plan 2011

**EXECUTED** as a deed.

**Signed, sealed and delivered** for  
**THE COUNCIL OF THE CITY OF  
SYDNEY** (ABN 22 636 550 790) by  
its duly authorised officer, in the  
presence of:

\_\_\_\_\_  
Signature of witness

\_\_\_\_\_  
Name

456 Kent Street, Sydney NSW 2000  
\_\_\_\_\_  
Address of witness

**EXECUTED** by **CITY HOLDINGS PTY  
LIMITED** (ACN 140 080 824) in  
accordance with s127(1) of the  
Corporations Act 2001 (Cth):

**EXECUTED** by **MARKHAM REAL  
ESTATE PARTNERS (GREEN  
SQUARE) PTY LIMITED** (ACN 631  
478 227) in accordance with s127(1)  
of the Corporations Act 2001 (Cth):

\_\_\_\_\_  
Signature of officer

\_\_\_\_\_  
Name of officer  
Authorised delegate pursuant to  
section 377 of the Local Government  
Act 1993

\_\_\_\_\_  
Position of officer

\_\_\_\_\_  
Signature of sole director/secretary

Vincent Muriti

\_\_\_\_\_  
Name

---

Signature of director

---

Signature of director/secretary

---

Name

---

Name

**ANNEXURE A**

**Public Benefits – additional plans and specifications**

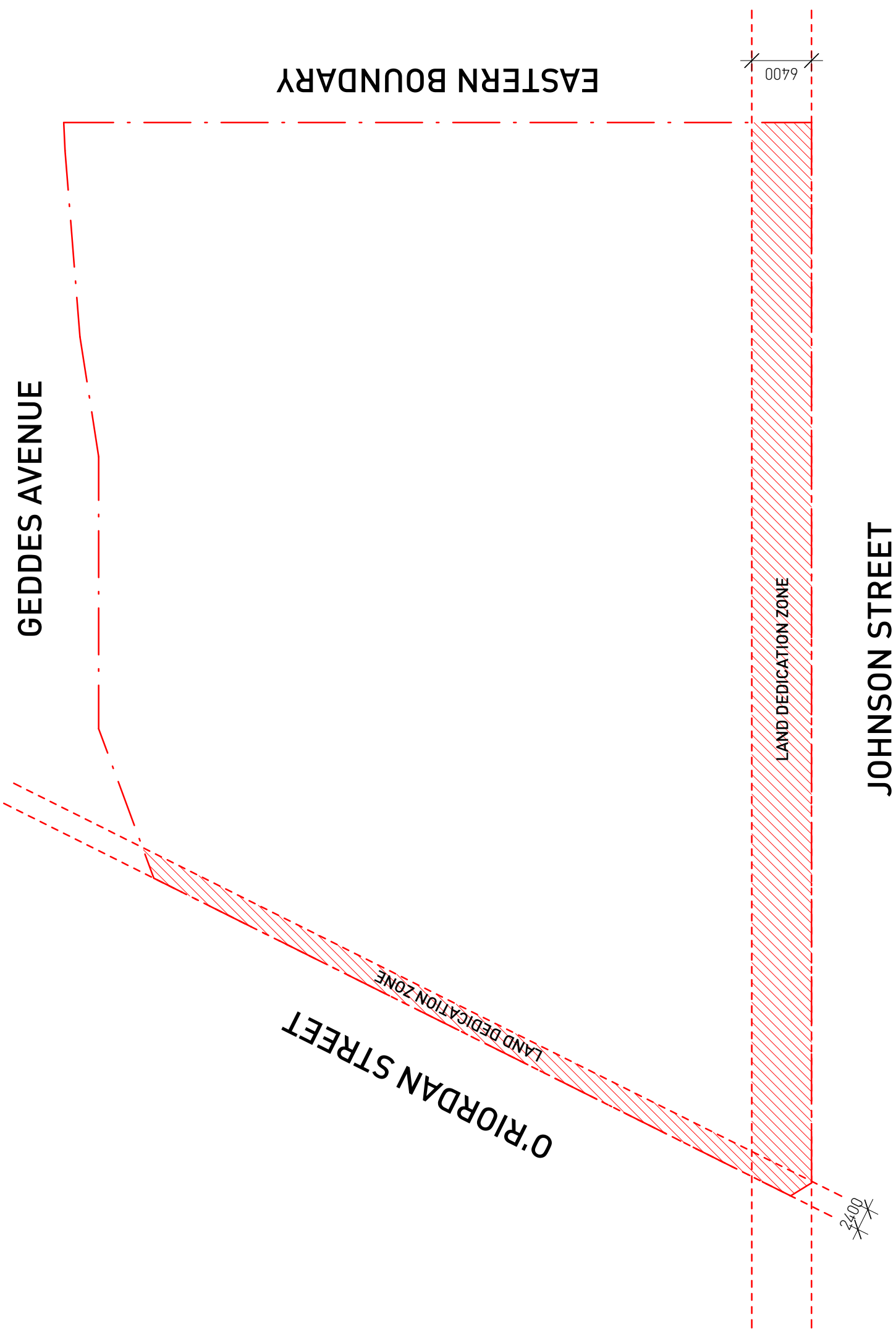

LAND DEDICATION ZONE 902 SQM



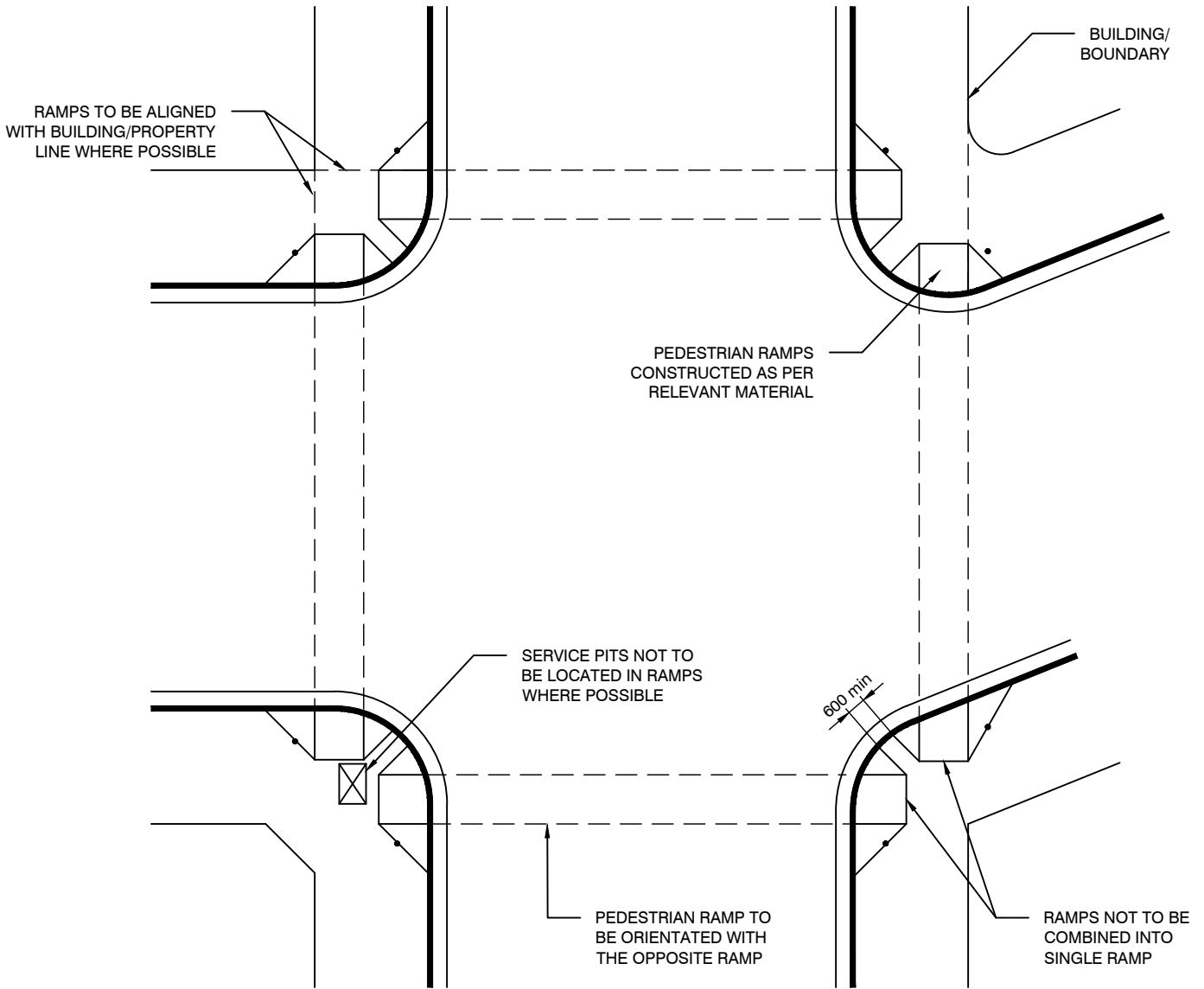

PLAN  
1:200

**NOTE:**

1. FOR SIGNALISED INTERSECTION TYPE AND LOCATION OF THE POLES, DIRECTION OF THE PEDESTRIAN CROSSING AND RAMPS SHALL BE APPROVED BY CITY OF SYDNEY TRAFFIC OPERATION TEAM PRIOR TO ANY CHANGES. CONSULTATION AND OBTAINING APPROVAL FROM RMS ALSO MAY BE REQUIRED.
2. FOR ANY PEDESTRIAN CROSSING AT THE INTERSECTION SITE SPECIFIC LIGHTING DESIGN SHALL BE PREPARED AND APPROVAL SHALL BE OBTAINED FROM CITY OF SYDNEY'S TECHNICAL SERVICES.

NOTE: ALL DIMENSIONS IN MILLIMETRES UNLESS OTHERWISE STATED

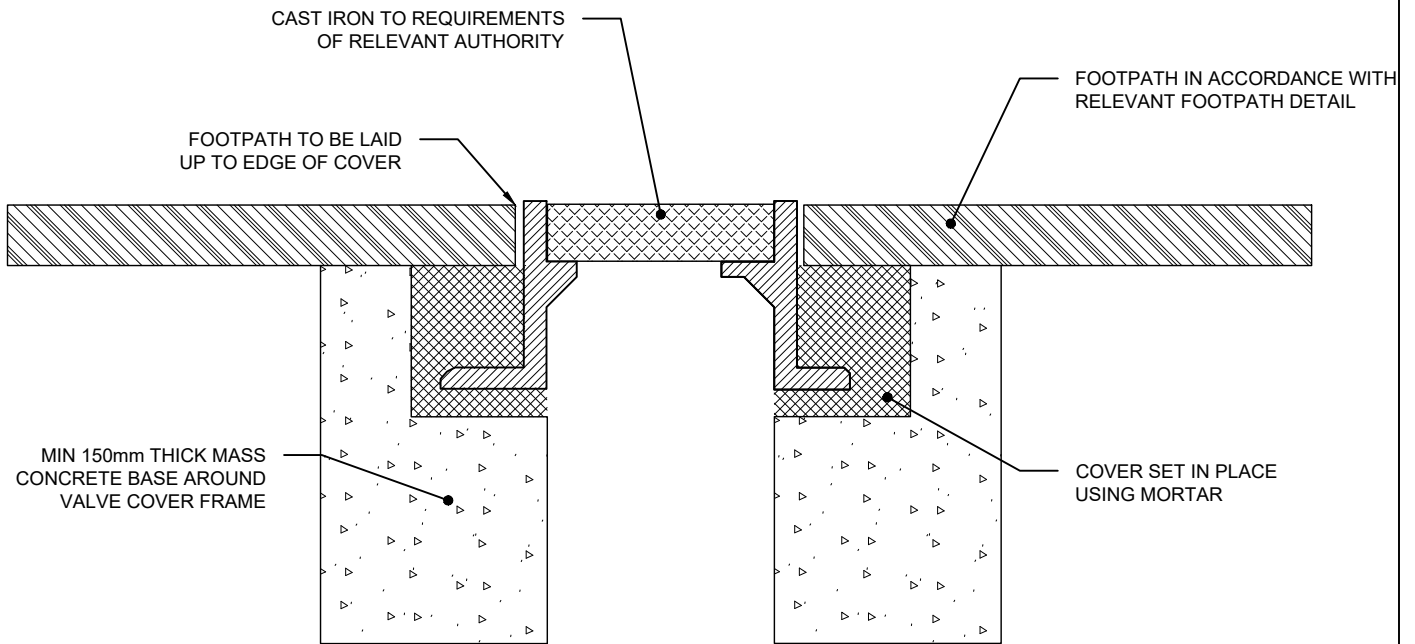

**NOTE:**

1. TO ENSURE THE SERVICE VALVE IS STILL ACCESSIBLE, THE RELEVANT AUTHORITY IS TO PROVIDE SIGN OFF / APPROVAL
2. FOR FIRE FIGHTING OPERATIONS, SERVICE VALVE COVERS ARE TO BE REINSTATED IN ACCORDANCE WITH THE WATER SUPPLY CODE OF AUSTRALIA WSA 03-2002-2.2 SYDNEY WATER EDITION VERSION, AND SPECIFICALLY DRAWINGS WAT-1305-V AND WAT-1306-V. ON COMPLETION THE NSWFB ZONE COMMANDERS EAST ONE (TEL: 0419 993 065) SHOULD BE CONTACTED TO ARRANGE TESTING TO ENSURE COMPLIANCE. TYPICALLY, THE CBD HAS SCREW HYDRANTS WHILST OUTSIDE CBD, SPRING HYDRANTS ARE USED.
3. WHERE PIT LID IS GREATER THAN 300mm IN ANY DIRECTION, AN INFILL LID IS TO BE USED.

SECTION 1:5

NOTE: ALL DIMENSIONS IN MILLIMETRES UNLESS OTHERWISE STATED

**TYPICAL PLAN**

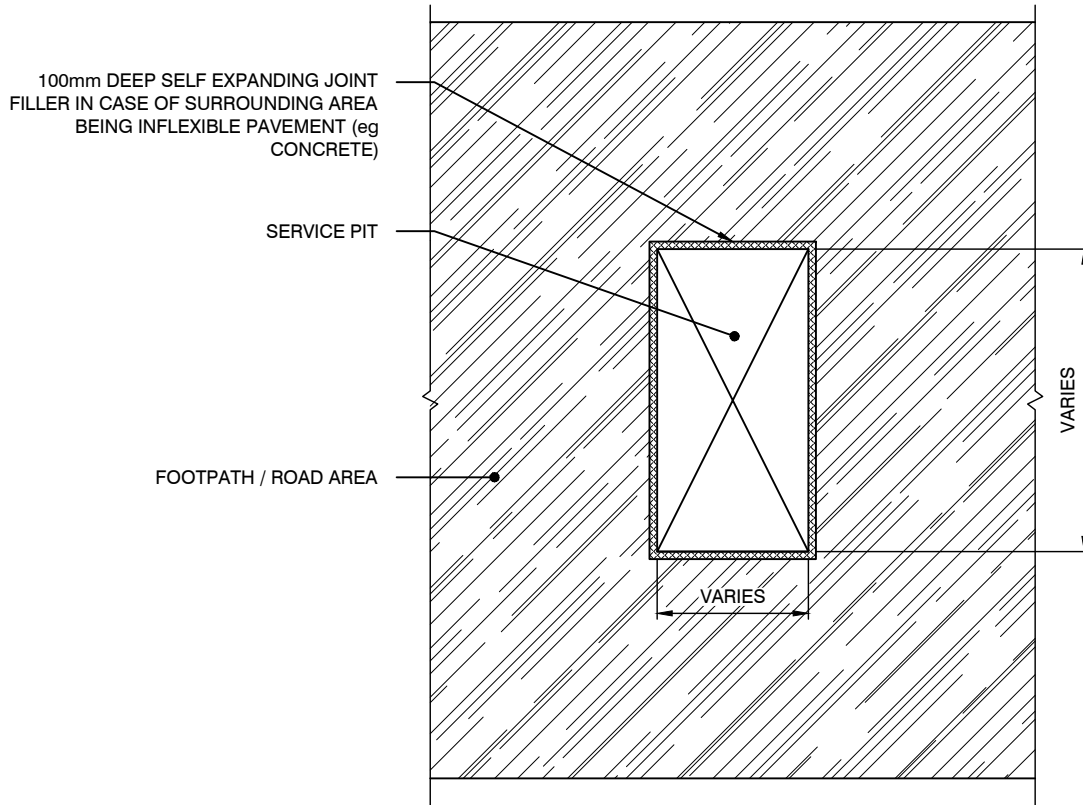

**FLEXIBLE PAVEMENT ELEVATION**

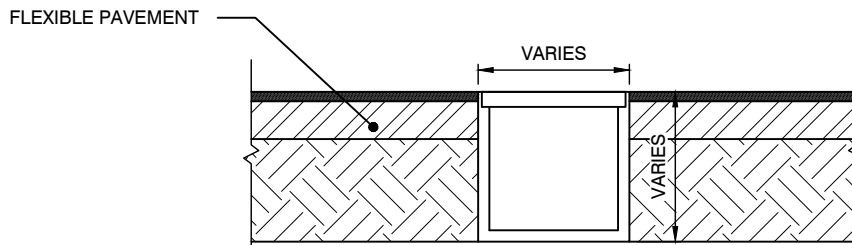

**RIGID PAVEMENT ELEVATION**

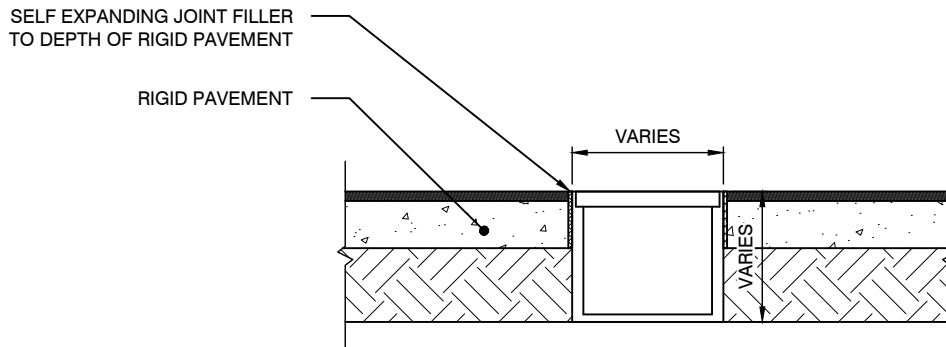

SCALE 1:20

NOTE: ALL DIMENSIONS IN MILLIMETRES UNLESS OTHERWISE STATED

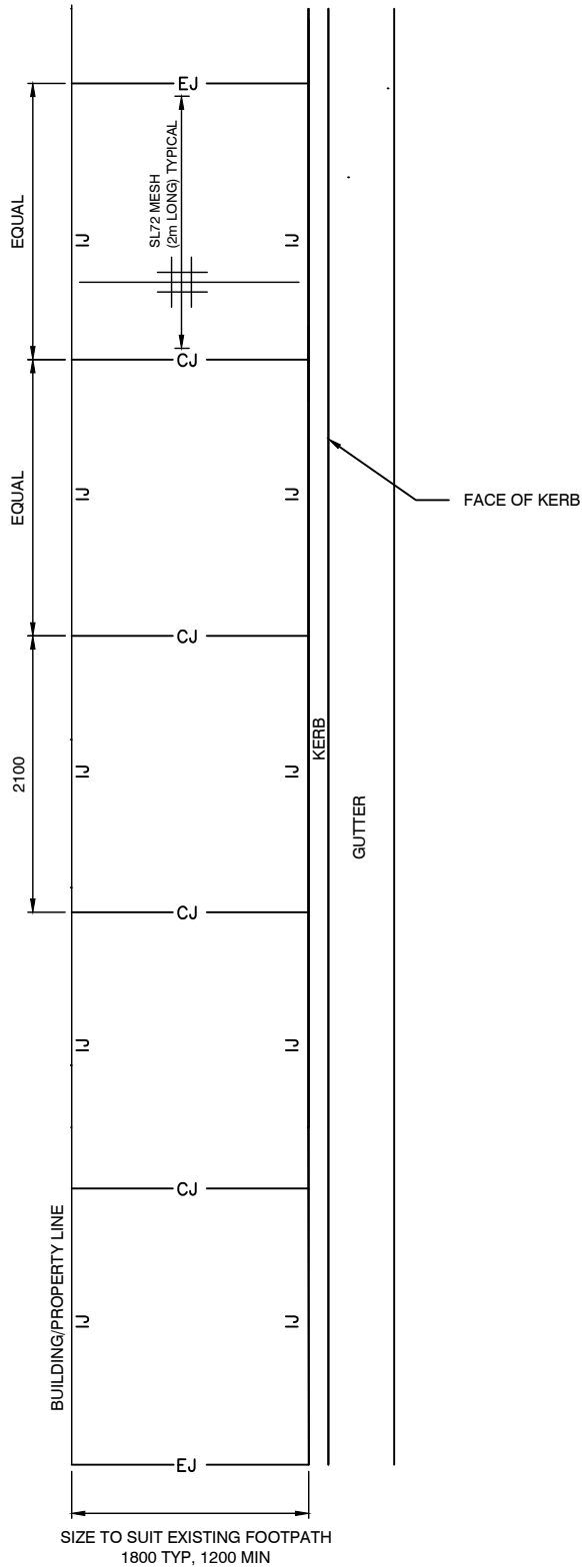

**NOTE:**

1. ALL EXPOSED CONCRETE SURFACES MUST BE FINISHED WITH A MEDIUM BROOM FINISH GENERALLY PERPENDICULAR TO THE DIRECTION OF TRAVEL.
2. ALL CONCRETE SLABS MUST HAVE A JOINT ALONG THE BUILDING LINE, KERB LINE AND ANY PENETRATIONS (EXCEPT WHEN USING BRICK KERBS).
3. ANY FOOTPATH THAT MAY BE SUBJECT TO VEHICULAR LOADS (SUCH AS GARBAGE TRUCKS IN NARROW LANES OR AT INTERSECTIONS WITH A TIGHT TURNING CIRCLE WHERE VEHICLES MAY MOUNT THE FOOTWAY) MUST HAVE AT LEAST 150mm THICK REINFORCED CONCRETE BASE (SL72).
4. CONCRETE FOOTWAYS TO BE A MINIMUM OF 1.2m WIDE, OR AS DIRECTED BY COUNCIL.
5. TYPICALLY ALLOW FOR EXPANSION JOINTS AT 12m (MAX) SPACING AND CONTRACTION JOINTS AT THE LESSER OF 6m OR 1.5 TIMES THE PAVEMENT WIDTH SPACING.

**LEGEND**

- |    |                    |
|----|--------------------|
| CJ | CONTRACTION JOINTS |
| EJ | EXPANSION JOINTS   |
| IJ | ISOLATION JOINTS   |

NOTE: ALL DIMENSIONS IN MILLIMETRES UNLESS OTHERWISE STATED

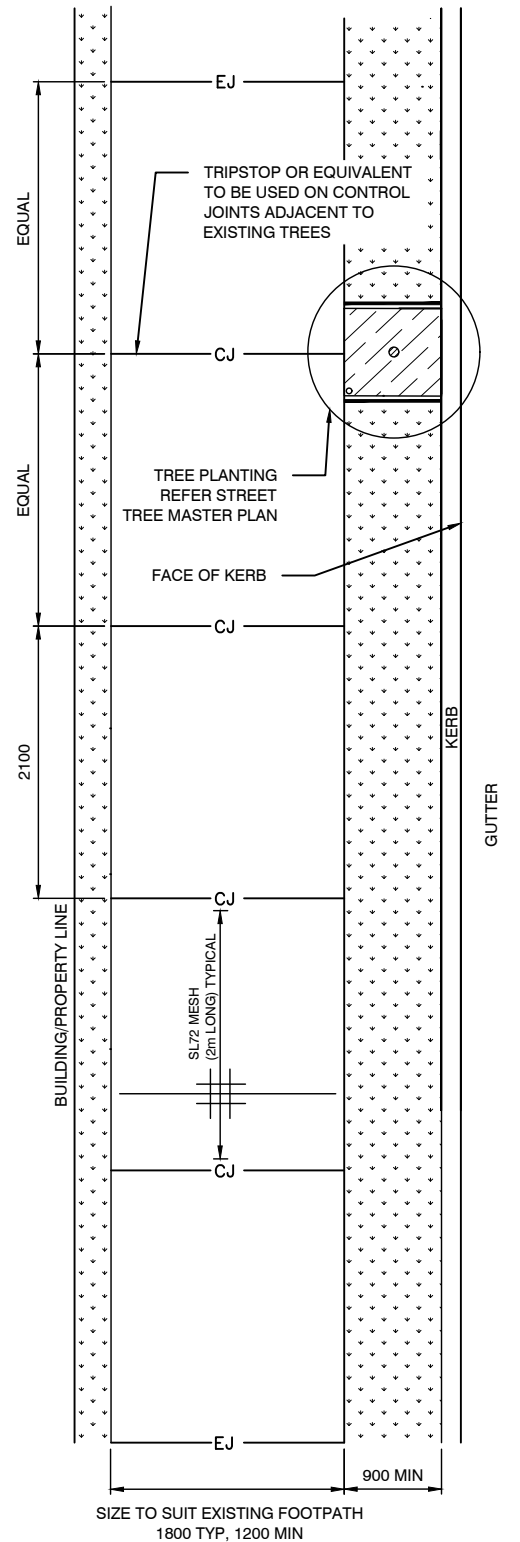
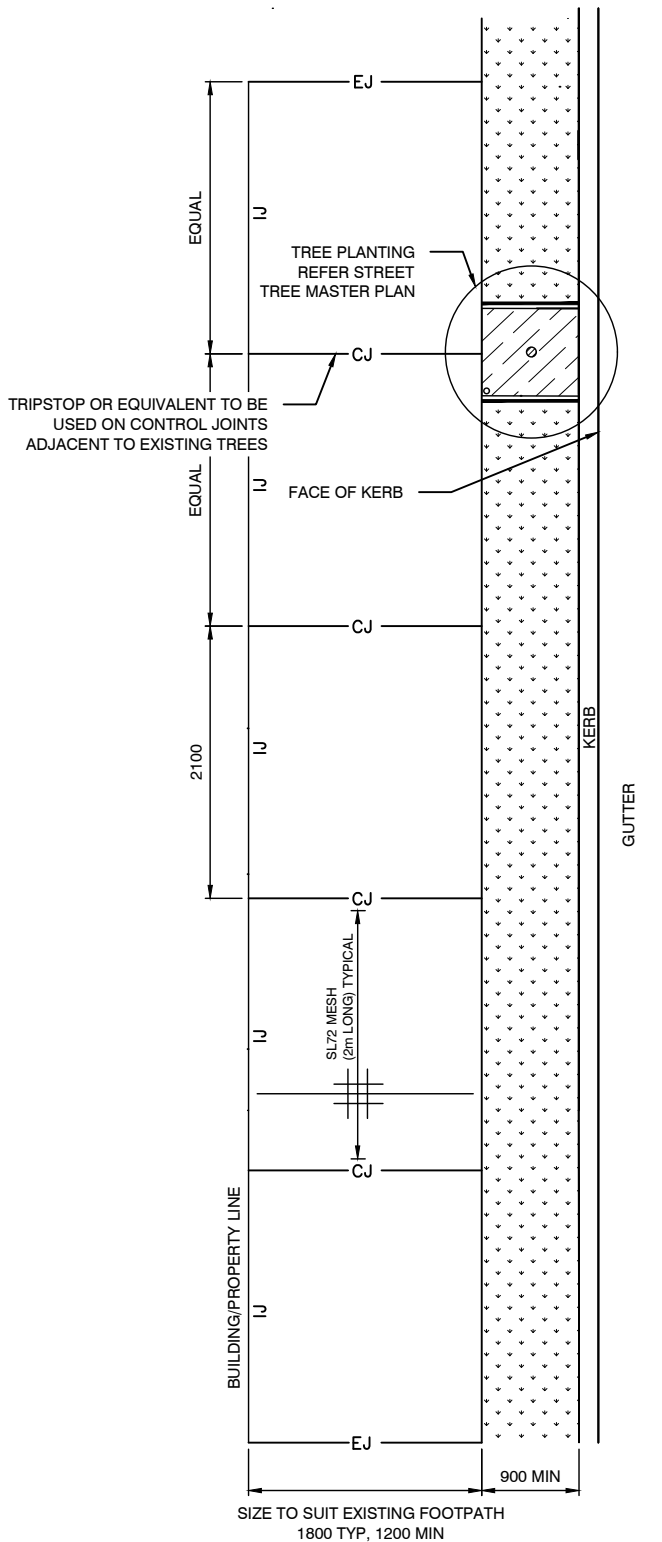

**NOTE:**

1. DETAIL ONLY TO BE USED IF MATCHING EXISTING, CITY REPRESENTATIVE TO APPROVE.
2. ALL EXPOSED CONCRETE SURFACES MUST BE FINISHED WITH A MEDIUM BROOM FINISH GENERALLY PERPENDICULAR TO THE DIRECTION OF TRAVEL.
3. ALL CONCRETE SLABS MUST HAVE A JOINT ALONG THE BUILDING LINE, KERB LINE AND ANY PENETRATIONS (EXCEPT WHEN USING BRICK KERBS).
4. ANY FOOTPATH THAT MAY BE SUBJECT TO VEHICULAR LOADS (SUCH AS GARBAGE TRUCKS IN NARROW LANES OR AT INTERSECTIONS WITH A TIGHT TURNING CIRCLE WHERE VEHICLES MAY MOUNT THE FOOTWAY) MUST HAVE AT LEAST 150mm THICK REINFORCED CONCRETE BASE (SL72).
5. CONCRETE FOOTWAYS TO BE A MINIMUM OF 1.2m WIDE, OR AS DIRECTED BY COUNCIL.
6. TYPICALLY ALLOW FOR EXPANSION JOINTS AT 12m (MAX) SPACING AND CONTRACTION JOINTS AT THE LESSER OF 6m OR 1 TO 1.5 TIMES THE WIDTH OF FOOTPATH SPACING IN PLAIN CONCRETE FOOTPATHS.

**LEGEND**

CJ	CONTRACTION/CONTROL JOINTS
EJ	EXPANSION JOINTS
IJ	ISOLATION JOINTS
	GRASS/PLANTED VERGE

NOTE: ALL DIMENSIONS IN MILLIMETRES UNLESS OTHERWISE STATED

PATH/GARDEN

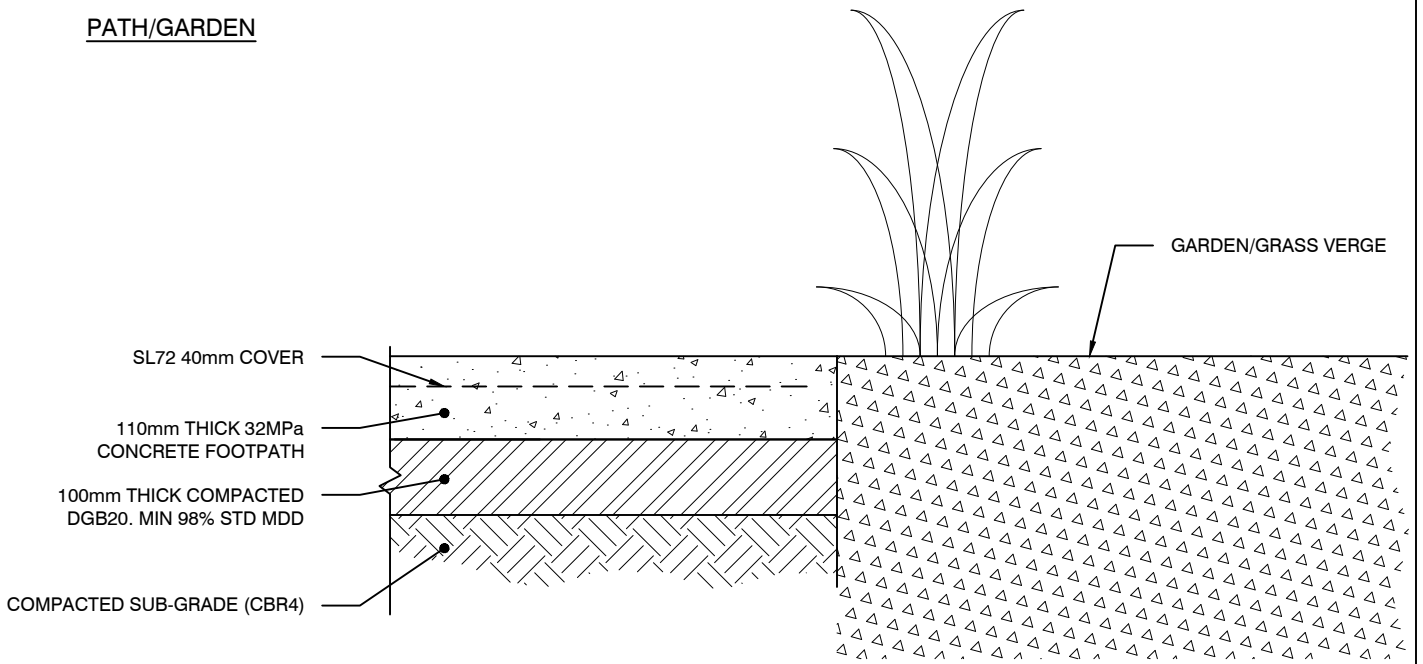

PATH/BUILDING LINE

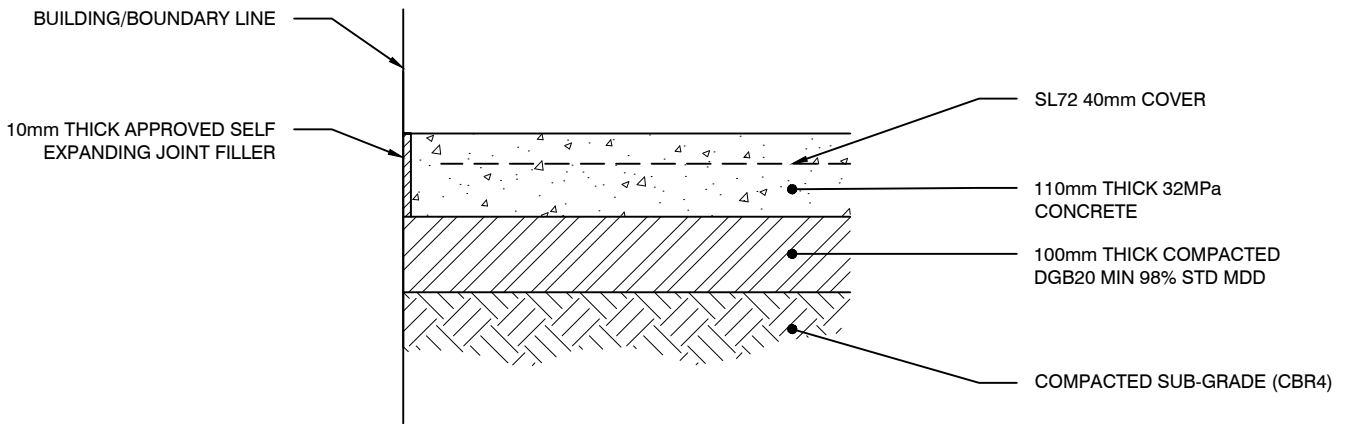

PATH/KERB

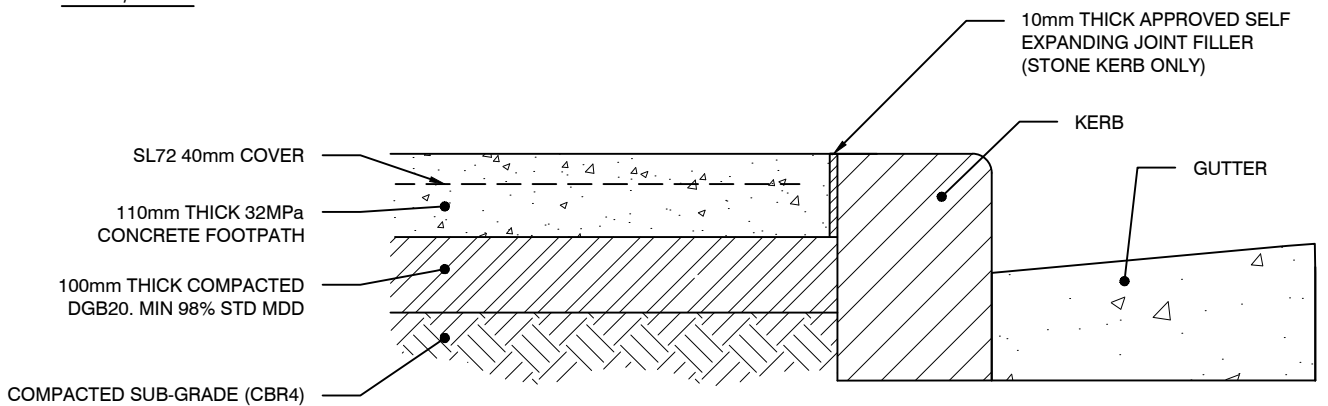

SECTION 1:10

NOTE: ALL DIMENSIONS IN MILLIMETRES UNLESS OTHERWISE STATED

**EXPANSION JOINT**

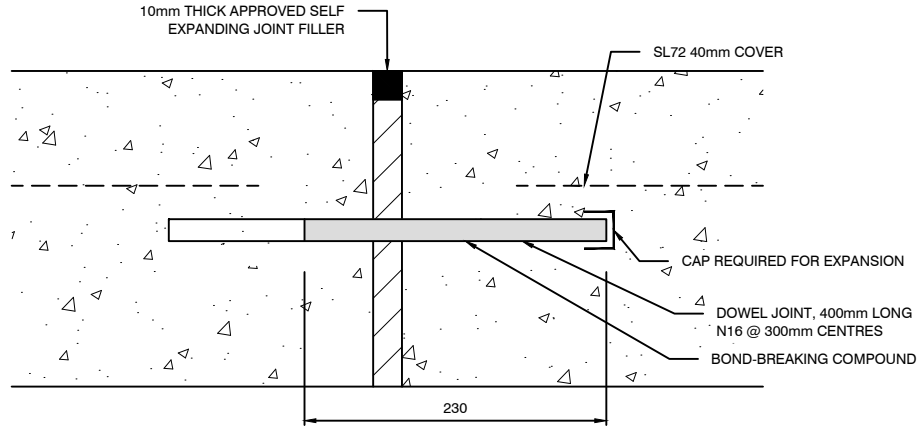

**NOTE:** BOND-BREAKING COMPONENT AND END CAP MAY BE REPLACED WITH A PURPOSE-MADE DOWEL SLEEVE.

**CONTRACTION/CONTROL JOINT**

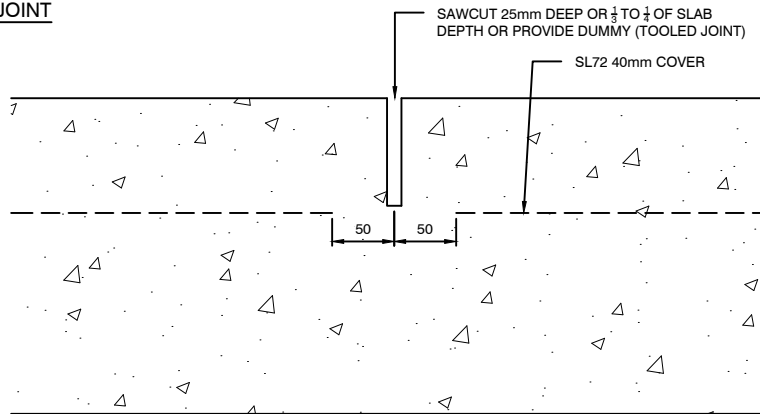

**CONSTRUCTION JOINT**

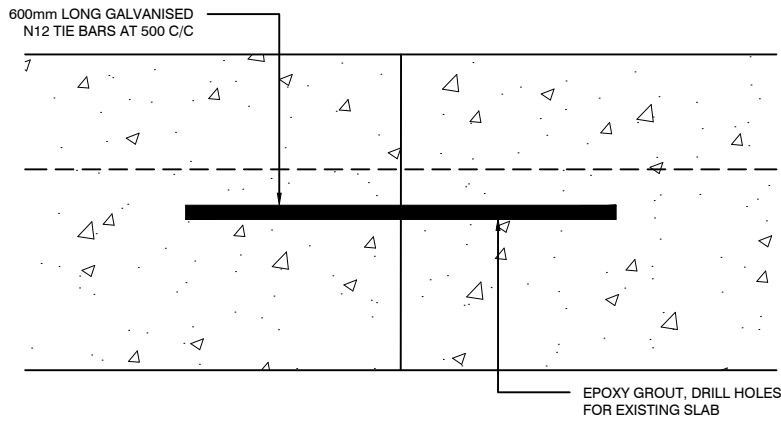

**ISOLATION JOINT**

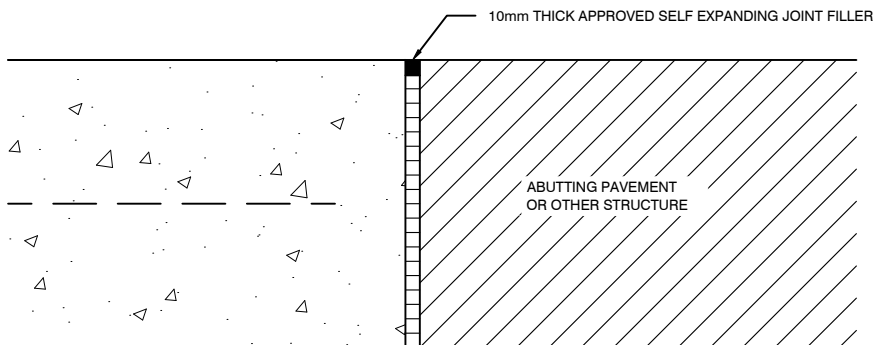

**NOTE:** ALL DIMENSIONS IN MILLIMETRES UNLESS OTHERWISE STATED

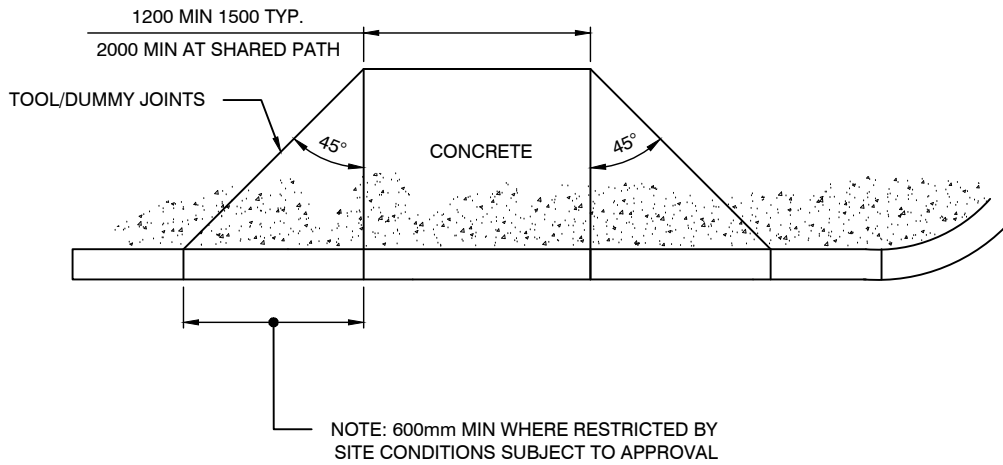

PLAN 1:50

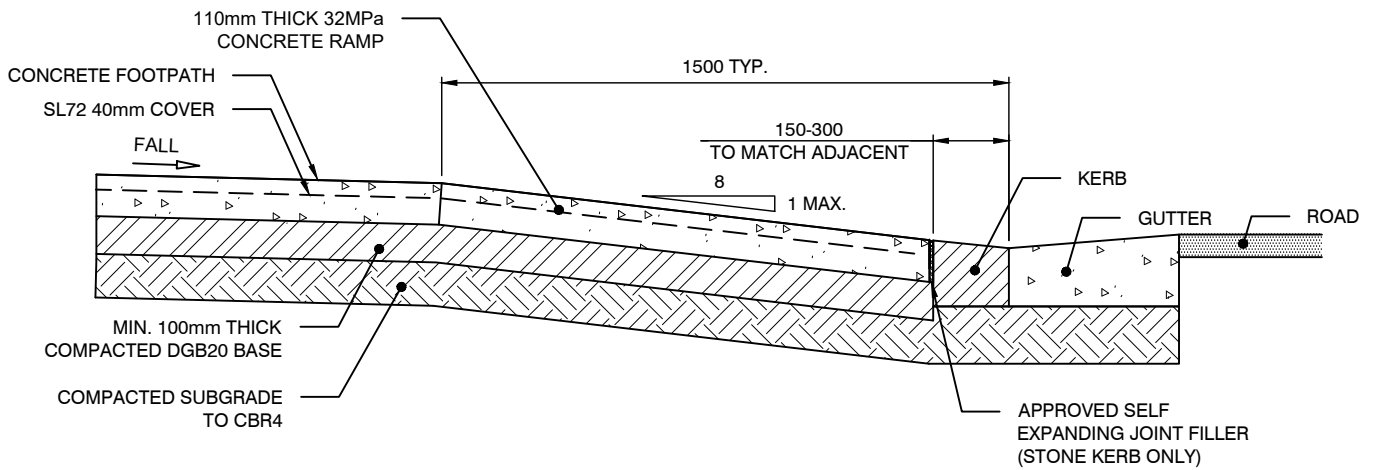

SECTION 1:20

NOTES:

1. ALL DIMENSIONS IN MILLIMETRES UNLESS OTHERWISE STATED.
2. THE 45° WING ANGLE ON KERB RAMPS IS THE GENERAL STANDARD AND RMS RECOMMENDATION. IF RESTRICTED BY SITE CONDITIONS, THE WING ANGLE CAN BE REDUCED AND DESIGNED TO SUIT SUBJECT TO APPROVAL.



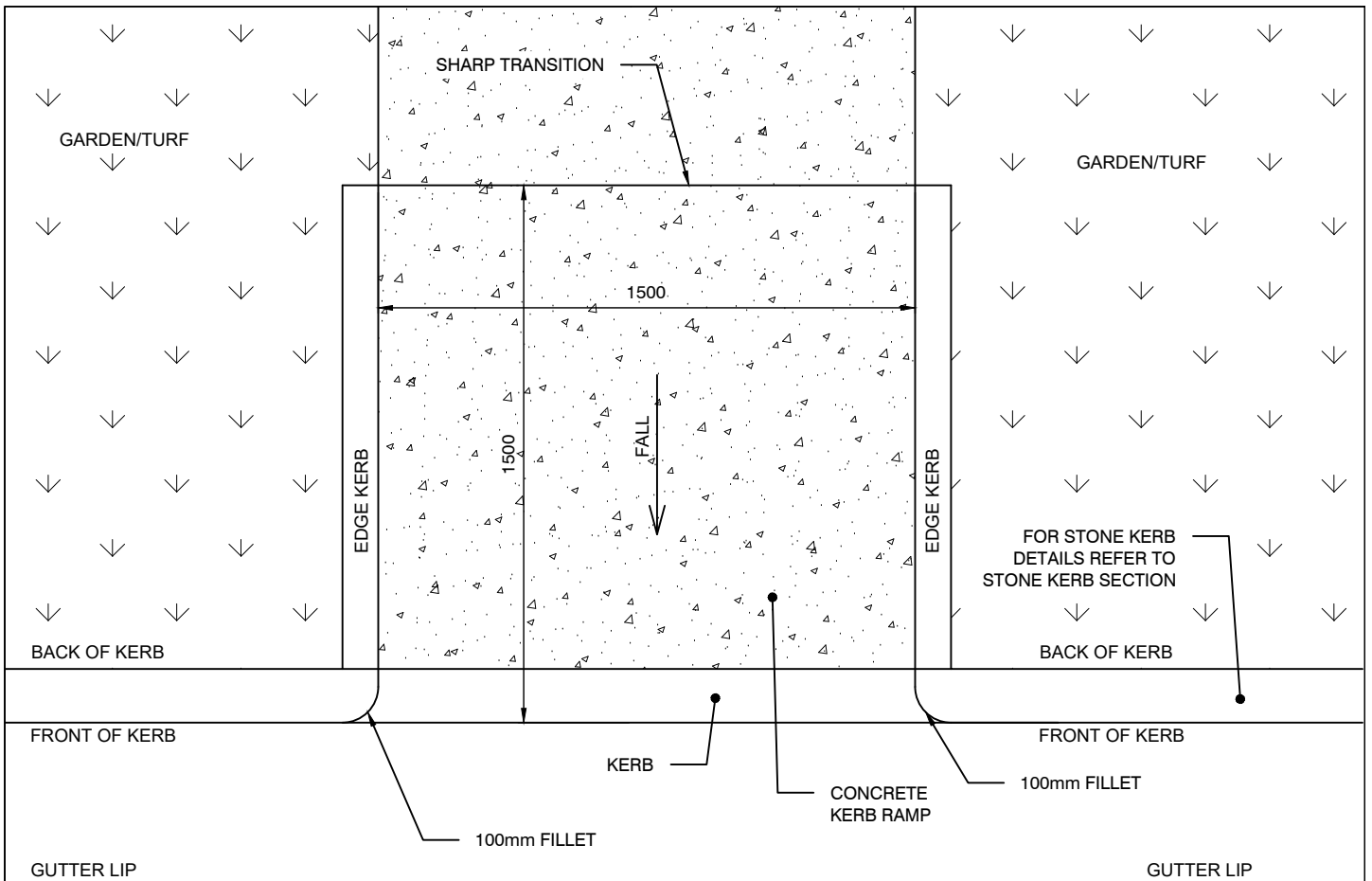

PLAN 1:20

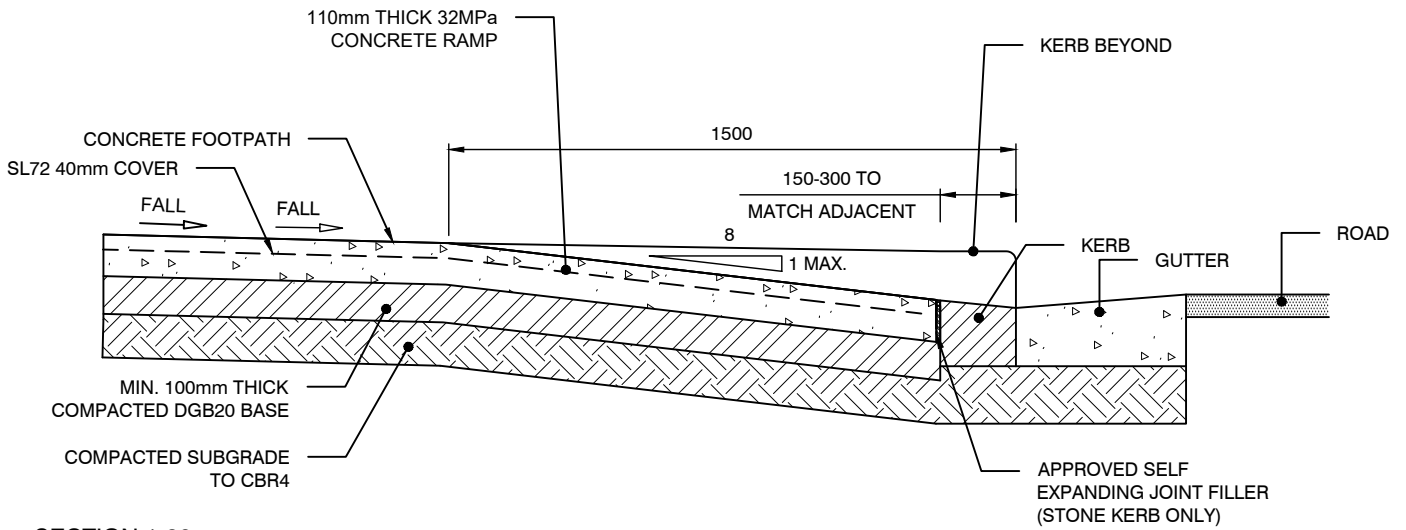

NOTE: ALL DIMENSIONS IN MILLIMETRES UNLESS OTHERWISE STATED

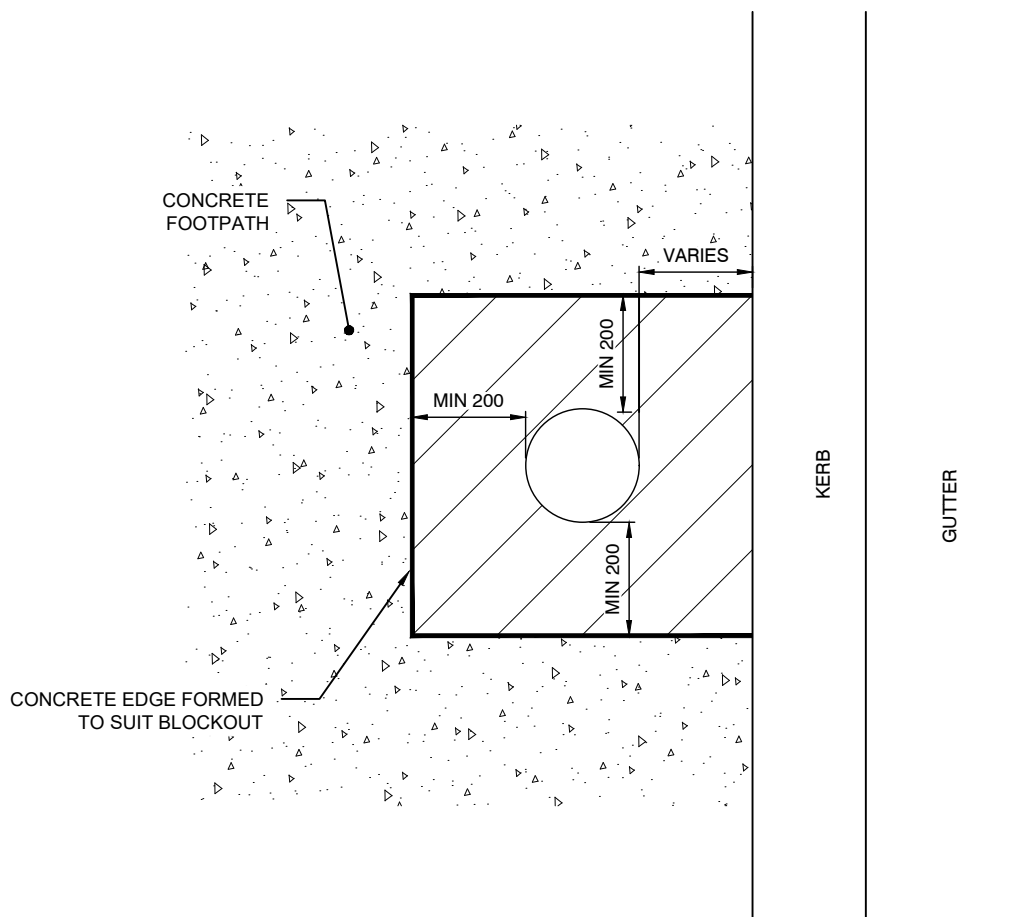

PLAN 1:20

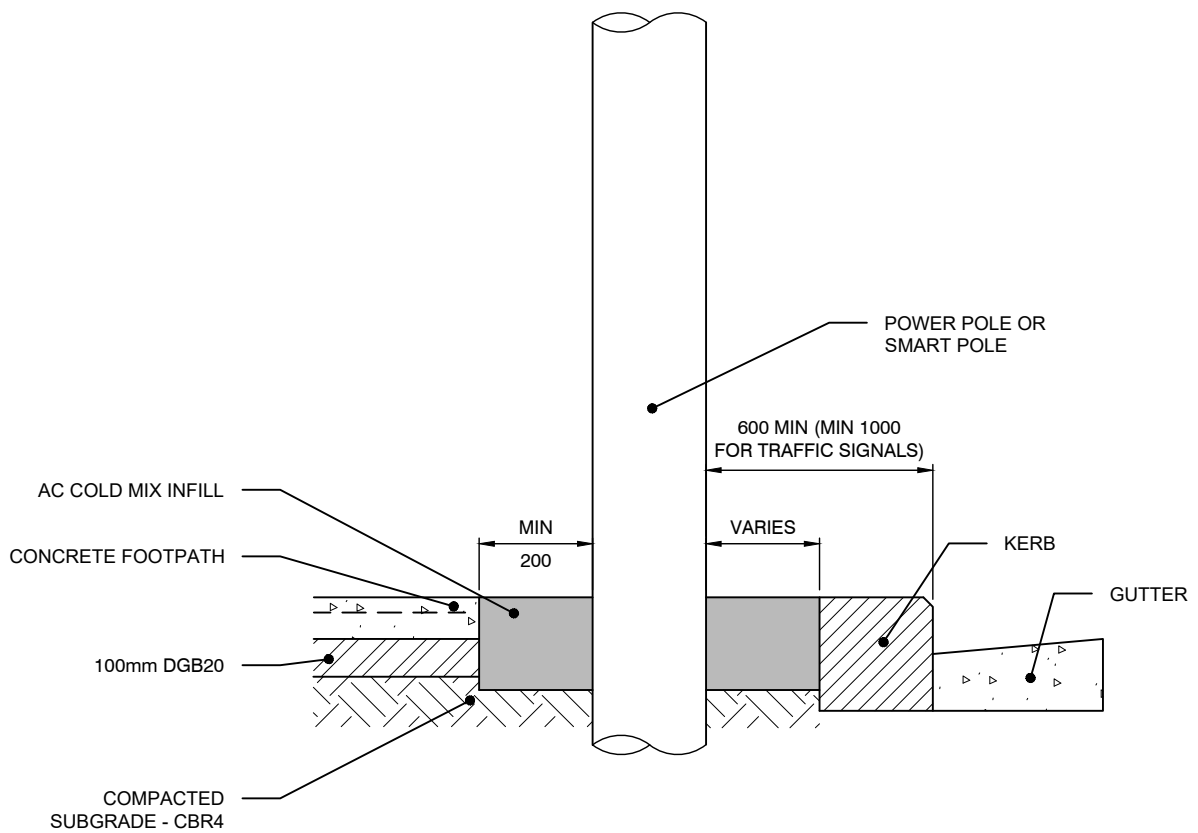

SECTION 1:20

NOTE: ALL DIMENSIONS IN MILLIMETRES UNLESS OTHERWISE STATED

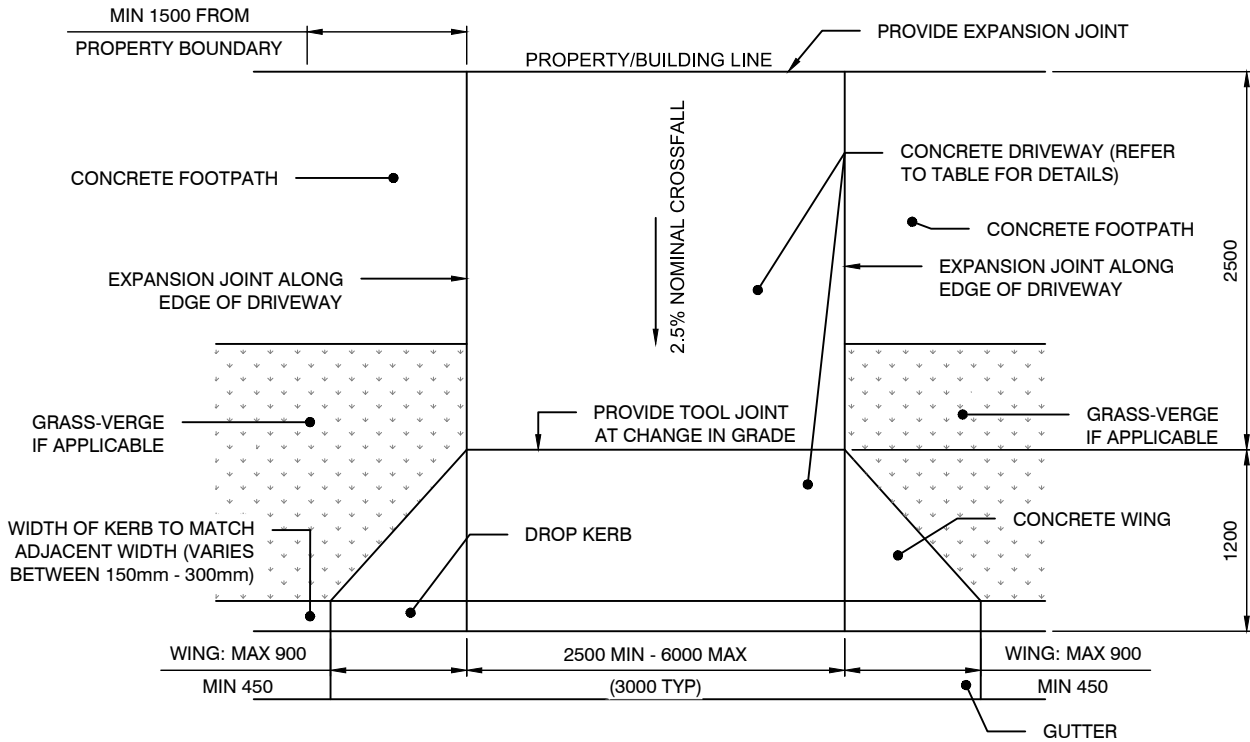

**NOTES:**

1. DRIVEWAY TO BE GENERALLY PERPENDICULAR TO KERB LINE, UNLESS APPROVED OTHERWISE.
2. VERTICAL AND HORIZONTAL CLEARANCE SHALL BE CHECKED BY THE DESIGNER IN ACCORDANCE WITH AS2890.1.
3. FOR NARROW FOOTPATHS LENGTH OF RAMP TO BE AS SHORT AS POSSIBLE, OR LAYBACK ONLY TO BE USED IN APPROVED APPLICATIONS.
4. FOR DRIVEWAYS WIDER THAN 6.0m A TOOL JOINT SHALL BE PROVIDED ALONG THE CENTRE OF THE DRIVEWAY.
5. DRIVEWAY CONCRETE SHALL BE WOOD FLOAT FINISHED.

**PLAN  
1:50**

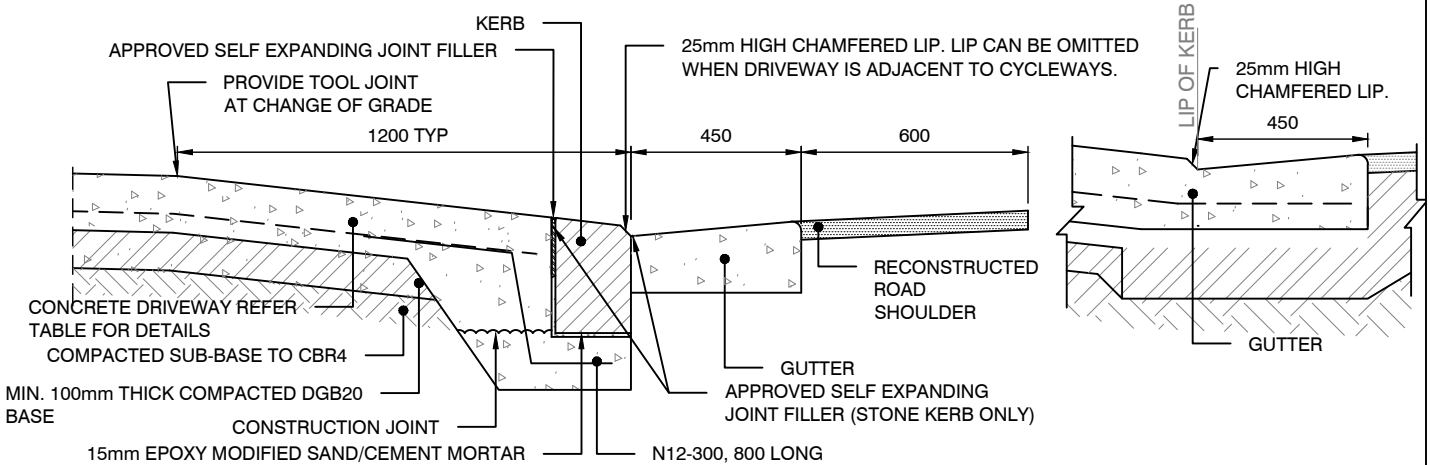

**SECTION ( STONE KERB)  
1:20**

**SECTION ( CONCRETE KERB)  
1:20**

DRIVEWAY SPECIFICATIONS			
DRIVEWAY USE	CONCRETE STRENGTH	THICKNESS	REINFORCEMENT
SINGLE RESIDENTIAL	32MPa	150mm	SL82
MULTI RESIDENTIAL	32MPa	200mm	SL82
COMMERCIAL/ INDUSTRIAL	32MPa	250mm	TWO LAYERS SL82

NOTE: ALL DIMENSIONS IN MILLIMETRES UNLESS OTHERWISE STATED

26 June 19

## APPLICANT'S PUBLIC BENEFIT OFFER IN CONNECTION WITH A DEVELOPMENT APPLICATION

This is an offer by: **Markham Real Estate Partners (Green Square) Pty Ltd.**

For: **22 O'Riordan Street, Alexandria**

At: **[insert date]**

This offer has been made with the consent of the registered owner(s) of the land.

The general nature and extent of the provision to be made under the offer, the time or times and the manner by which the provision is to be made are as follows:

- Setback and dedication of 2.4m of land along O'Riordan Street of the site (approx. 199sqm – subject to detailed survey);
- Public domain embellishment works to these land dedications in accordance with Council's Public Domain Guidelines (value of these works to be agreed with Council);
- Cash Contribution to Green Square Town Centre @ \$100/sqm; and
- Cash Contribution to community infrastructure within the wider Green Square Urban Renewal Area.

The Tables below provide further details of the material public benefits:

Site Area		General Scope of Works	Value (incl. GST)
Base FSR / FSA permitted by LEP/DCP	<b>1.5:1 / (11,154m<sup>2</sup>)</b>	Green Square Town Centre Contribution	\$739,500
Amount of additional FSR / FSA sought:-	<b>1:1 / (7,436m<sup>2</sup>)</b>	Footways	<u>Land Dedication</u> To be agreed and costed  <u>Works in Kind</u> To be agreed and costed
Additional FSR rate (incl. GST):-  <del>(a) Residential Use</del> <del>(b) Retail Use</del> (c) Non-Residential Use	<b>\$200 per 1m<sup>2</sup></b>	Contribution to Green Square Urban Renewal Precinct	Any remaining value

<b>Total Value of additional FSR</b>	<b>\$1,479,000</b>	<b>Total Value of Scope of Works</b>	<b>\$1,479,000</b>
--------------------------------------	--------------------	--------------------------------------	--------------------

Assuming Council agrees to the above proposed public benefits, the proponent will undertake the following additional work prior to drafting and finalisation of any Voluntary Planning Agreement:

- Detailed survey of land proposed to be dedicated to Council to obtain accurate sqm; and

It is intended that the benefits under the offer do not include development contributions under section 7.11 of the Environmental Planning and Assessment Act 1979.

It is intended that should development consent be granted, this offer will be consolidated and crystallised into a voluntary Planning Agreement with the Council. The agreement will comply with the requirements of the Environmental Planning and Assessment Act and Regulations and contain mechanisms for completion of any works and / or land dedication. The Planning Agreement may be registered by the Registrar-General.

Name of Applicant .....

Signature of Applicant .....

Date .....

Name of all Registered Owner(s) .....

Signature of all Registered Owner(s) .....  
*(Owners which are companies must indicate consent by signing under seal or as otherwise authorised under Corporations Law.)*

Date .....